



Western Gage Corporation



Dimensional Gage Buyer's Guide 46

Fast, accurate . . . cost effective

At Western we focus on air and electronic gages that, with a minimum amount of operator skill, provide fast, accurate and cost effective measurements of parts in production shop floor environments.

For fast, accurate measurement of internal and external diameters consider using one of our dimensional air gages. We've designed and manufactured dimensional air gages for over 40 years and know what works well and what doesn't. Air gage ranges are limited, so they are not for every application, but for highly precise parts there is nothing better.

Besides checking I.D.'s and O.D.'s, we have proven air gage designs for checking taper angle, bore straightness, concentricity, thickness, perpendicularity, center distance and parallelism. Fabricated in Western's gage manufacturing shop, they are fast, accurate and much less expensive than using coordinate measuring machines, roundness test tables, or surface profilometers to check these kinds of features. Does it make sense to employ expensive pieces of capital equipment when a fast, accurate custom built gage will do the job?

Readouts for fast, accurate gages are where we excel with our microprocessor based instruments. MilliCheck readouts with high resolution LCD displays are ideal replacements for single channel mechanical air gage instruments. Versatile Micro IIi readouts have both bargraph and digital displays, incorporate RS-232 serial and USB outputs, and can handle up to four inputs. More complex gaging applications utilize Western's model AEK II air-electric converters coupled to PC computer or GageChek displays.







Not all workpiece features are best measured with air gage sensors; hard contact gages are better for rough surface finishes and for applications requiring extended gaging ranges. For these applications, we use our LVDT probes coupled with LVDT electronic modules in Micro IIi readouts.

Of course dimensional gages are no better than the masters used in their calibration. At Western, we operate our own gage finishing and calibrating laboratory where ANSI/ASME standard and custom setting masters are lapped and calibrated with NIST traceable standards under highly precise environmental controls.





We believe that fast, accurate measurement is a key part of precision manufacturing processes. Our focus is to provide value to our customers by improving this facet of their operations.

Donald E Moors,
President

GAGE READOUTS

	MilliCheck	6
	Micro Ili	8
	Air-Electric Converter.	11
	GageChek	12
	PC Gage Station	13
	Readout Accessories	14

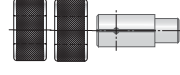
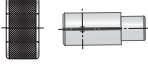
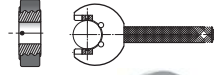



GAGING MEMBERS & SETTING MASTERS

	Air Gages for Internal Diameters	16
	Air Gage for External Diameters.	17
	Dual Master Air Probe Dimensional Data	18
	Single Master Air Probe Dimensional Data . .	20
	Air Ring Gage & C-Gage Dimensional Data . .	22
	Setting Masters	24

Air Gage Series Classification & Interchangeability . . 26

Air Gage & Setting Master Order Codes 27

PRODUCTION GAGING SOLUTIONS

	Taper Gages	28
	Custom Air Probes.	30
	Flatness & Thickness Gages.	31
	Electronic / LVDT Gages	34

CAPABILITY HIGHLIGHTS

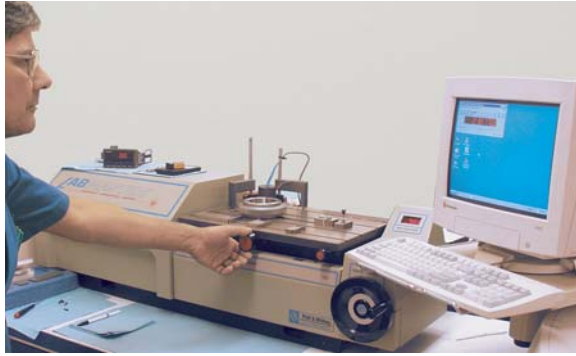

- **GAGE DESIGN**

Engineering staff with extensive experience in design and fabrication of precision measuring instruments and calibration standards

- **MANUFACTURING**

High precision grind shop with ultra precision readouts. In-house hard chrome plating and heat treating assures quality and minimizes product lead times

- **GAGE LAPPING**

Proprietary O.D., I.D. and Flat lapping equipment are utilized in finishing master gages to ultra precision tolerances

- **CALIBRATION**

Metrology lab with precision temperature control and air filtering. Equipped with lab grade reference standards, electromechanical and laser interferometer calibration instruments

- **TESTING**

Pneumatic and electronic test benches for testing and calibrating of Gage Readouts

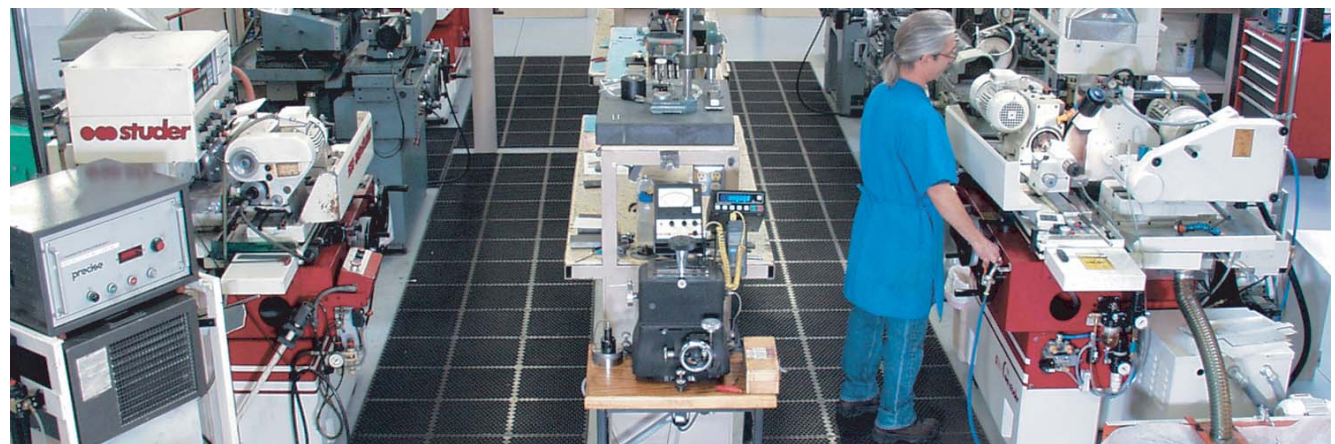
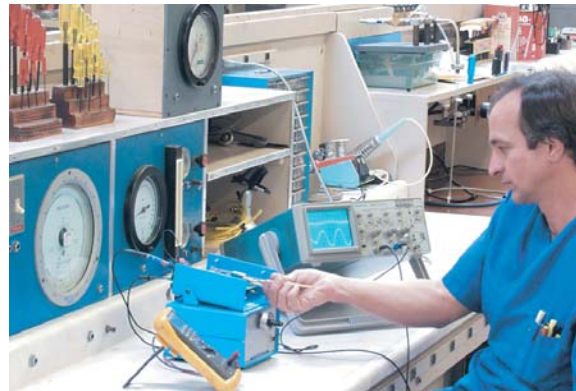

GAGE SENSOR TYPES

The choice of air gage or LVDT type requires evaluating how these sensors best fit the user's application.

Air gage sensors

Air gage sensors measure the backpressure created when an air nozzle is brought in close proximity to the workpiece; the air gage readout measures this pressure and displays the dimensional change in the air gap.

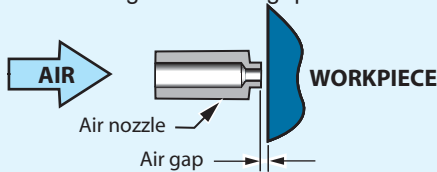

Non contact - The air nozzle throttles the air at the point the air exits the jet hole, thus the average height of a spot on the surface opposite the jet hole is sensed by the air readout. Since the nozzle does not contact the workpiece, wear does not directly affect the accuracy of the gage; moreover, the pressure of the air has a self cleaning effect on the workpiece, making air gages perform exceptionally well in shop floor environments.

Sensor size - Air nozzles can be made with jet holes from .010" to .100" (.25 to 2.54 mm), with .050" (1.25mm) being preferred for most applications. Multi-sensor gaging members are easily constructed by drilling interconnecting air passages to gaging nozzles.

Gaging ranges - Air gages have relatively limited ranges. For good linearity, the gaging range of an air gage member must be less than 8% of the jet hole size. For most applications, practical limits on air flow limit jet sizes to .079" (2 mm) and gaging ranges to .006" (.15 mm) or less. Furthermore, applications requiring exceptionally high accuracies, such as diametrical tolerance limits of .00008" (.002mm), are best measured by air gage members designed for ranges .0006" (.015 mm) or less.

Response time - depends on the volume of the air circuit and the size of the gaging nozzles. Response times can vary from less than 100 milliseconds to several seconds; except for gages with very small jet sizes, typical response times will be less than two seconds.

Cost - Air gage nozzles are less expensive than LVDT gaging cartridges. For applications that require the summing of inputs from two or more sensors they are significantly less expensive than LVDT gaging.

LVDT sensors

LVDT sensors measure the voltage developed in wire coils as a magnetic core attached to a stylus is displaced by the test surface; changes in this voltage are displayed as dimensional changes.

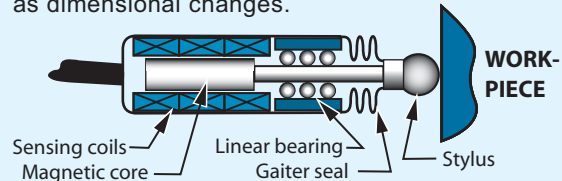

Hard contact - LVDT gages with a spherical stylus sense a point on the contacted surface, or with a flat stylus tip, the highest point on the surface is sensed. Contact gaging is generally preferred for gaging rough surface finishes and narrow lands. Contact gages, particularly those with flat stylus tips, tend to be more sensitive to surface contaminants.

Sensor size - Compared to air gage nozzles, LVDT gaging cartridges are relatively large and expensive. Sizes vary from 6 to 8 mm diameter (.236" to .315") and from 35 to 85 mm (1.38" - 3.35") in length. Multi-sensor applications are implemented by electronically interconnecting gaging cartridges at the readout instrument. The large size of LVDT sensors prohibit their use on internal diameters except for rather large bores. Gaging small bores requires the use of a motion transfer mechanism, adding to cost and decreasing the accuracy.

Gaging ranges - LVDT gages have significantly greater linear measuring range than air gages. Linearity of 1/2% over ± 1 mm ($\pm .040$ ") gaging range is typical. Highest resolutions are obtained when the gaging range is less than .05 mm (.002").

Response time - depends only on the time constants of the readout. Response times as short as 1 millisecond can be obtained with suitable electronics. LVDT gages are preferred for automated gages with very short cycle times.

Cost - Generally more expensive than air gaging, except where the extended range capability reduces the number of gages required for the application. Use LVDT gages for applications requiring hard contact or where an extended gaging range is beneficial.

Surface finish effects - The air gage senses the average height of the surface while the contact gage senses the peaks of the surface, which can result in a variance between measurements made by these two types of sensors on rough surfaces. This variance will be minimal or nonexistent on a part with a ground or honed surface, but may be significant on a machined part with a rough surface finish. In general this will not exceed the difference between the center line average surface roughness of the workpiece and that of the setting masters used to zero the gages.

AIR & ELECTRONIC GAGE READOUTS

MilliCheck & Micro Ii Readouts operate all popular makes of dual and single master type air gage members, as well as LVDT type electronic gages. Incorporating sealed controls, solid state pressure sensors, digital and bargraph LCD displays, these instruments perform exceptionally well on the shop floor as well as in metrology lab environments.

Air Gage Readout Block Diagram

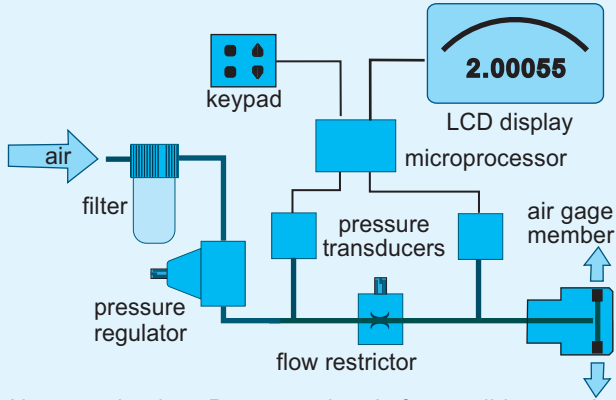

Air gage circuit - Pressure signals from solid state piezo-resistive pressure transducers are sent to a microprocessor where the bargraph and digital readings are calculated. Utilizing outputs from two transducers, one measuring the backpressure from the air gage nozzles, and one monitoring the regulator pressure, the microprocessor eliminates errors related to supply pressure variations. Being highly stable, Micro Ii & MilliCheck instruments can be operated using one or two setting masters. The adjustable flow restrictor incorporated in these instruments provides an exceptional range capability, accommodating gaging members with wide ranges of nozzle sizes and magnifications.

LVDT Readout Block Diagram

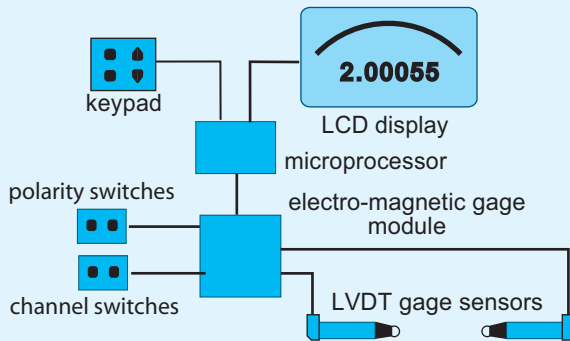

LVDT gage circuit - AC voltage is supplied to the LVDT gage sensors which return signals proportional to the displacement of the sensor styluses from their null voltage positions. The LVDT gage module processes the voltage from the sensors and directs the signal to the instrument's microprocessor where the bargraph and digital display values are calculated. Polarity and Channel switches provide capability to sum or difference inputs from the sensors.



MilliCheck model AEC 30-10 with dual master air probe and setting rings.



MilliCheck model AEC 30-E2 with VeeCheck O.D. gage and setting master

MilliCheck gage readouts feature high resolution LCD bargraphs and four decade digital displays. Designed for low power consumption, they operate from either standard "D" Cell batteries or AC power adapters. With user selectable multiple inch and metric gaging ranges, these readouts provide economical replacements for mechanical air gage instruments. They can be configured for either LVDT type electronic gages or air gages.

See page 7 for specifications and order codes.

MILLICHECK TECHNICAL DATA

Bargraph display:

Circular 121 Segment LCD

Digital display: 4 Decade LCD

Features, front panel:

- Power-on
- Zero adjust
- Span adjust (dual master only)
- Tolerance markers
- Pneumatic Zero adjust (air gage modules only)
- Air status indicator

Features, rear panel:

- Inch - Metric selection
- Operator front panel lockout
- Auto on-off time select*
- Input polarity
- Scale selection (Field selectable scales are listed at the right.)

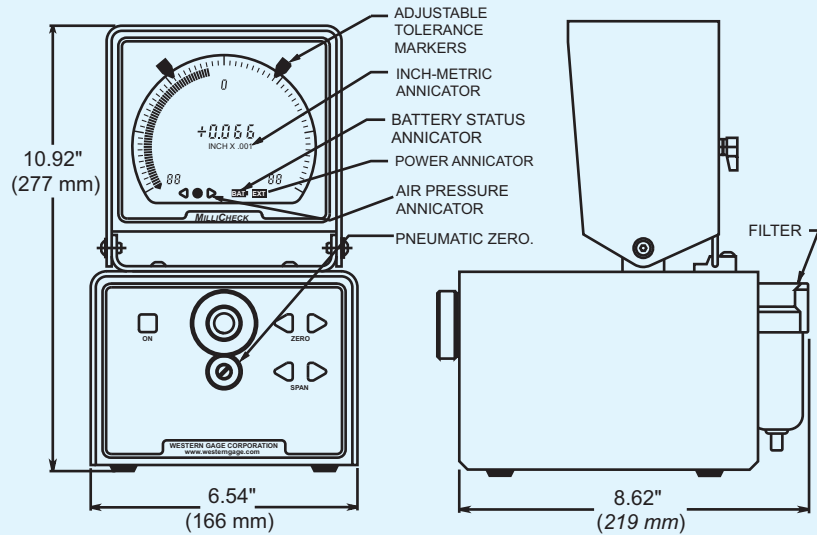

Weight: 10 Lbs (4.5 Kg)

Gage inputs Select gage type listed below and add a suffix to order code as shown at the bottom of this page.

- Series 10 Air gage** -- All dual master type air gages.
- Series 60,70 or 80 Air gage** -- Single master type air gages.
- E1, E2 or E3 High resolution LVDT** -- use on scale ranges $\pm 0.0015"$ or ± 0.030 mm or less.
- E4, E5, or E6 Extended range LVDT** -- Use on ranges $\pm 0.00075"$ or ± 0.15 mm or greater.

Power:

- Internal Battery*-- 4 "D" cells
- External power adapters, specify one:
 - 110/125 VAC - 9 VDC, 60 Hz, adapter is standard.
 - 100-240 VAC - 9VDC, 47-63 Hz, universal adapter with optional field changeable foreign outlet plugs.

Air gage module requirements:

.5 to 2 SCFM @ 40 to 125 psi (The actual air flow depends on nozzle sizes and gaging ranges of the air gage members connected to the readout).

MilliCheck instruments incorporate an auto off mode to * extend battery life. Actuating the power button wakens the gage with no loss of calibration. The auto-off mode can be turned off when operating from external power.

MilliCheck scales -- inches			
Range Selector	Magnification	Resolution Analog	Resolution Digital
$\pm .00015$	30000	.000003	.000002
$\pm .00030$	15000	.000005	.000005
$\pm .00075$	6000	.000013	.00001
$\pm .0015$	3000	.000025	.00002
$\pm .003$	1500	.00005	.00005
$\pm .006$	750	.00010	.00005
$\pm .015$	300	.00025	.0001
$\pm .030$	150	.0005	.0001

MilliCheck scales -- millimeters			
Range Selector	Magnification	Resolution Analog	Resolution Digital
$\pm .003$	37500	.00005	.00005
$\pm .006$	18750	.00010	.0001
$\pm .015$	7500	.00025	.0002
$\pm .030$	3750	.0005	.0005
$\pm .060$	1875	.0010	.0010
$\pm .150$	750	.0025	.002
$\pm .300$	375	.005	.002
$\pm .600$	188	.010	.002

MilliCheck Order Codes:

AEC 3X - XX

Product category / model: **AEC 30** - 110/125 VAC 60 Hz
AEC 31 - 100/240 VAC 47/63 Hz
 (External power adapters)

Gage inputs: **-10** Air gage, dual master type, series 10
-60 Air gage, single master type, series 60
-70 Air gage, single master type, series 70
-80 Air gage, single master type, series 80
-E1, E4 LVDT Channel A only (High gain, Low gain)
-E2, E5 LVDT [Ch.A + Ch.B] (High gain, Low gain)
-E3, E6 LVDT [Ch.A - Ch.B] (High gain, Low gain)

MICRO IIi READOUTS



Micro IIi model AEQ 42-11-60 with single master type air probe and master ring provides fast and accurate inspection of internal diameters.

USB & RS-232 serial data ports are standard on all Micro IIi units.

Model AEQ 42-11-10 with Air probe connected to **Mini-Printer model IMP-24** via the RS-232 port is shown at right.

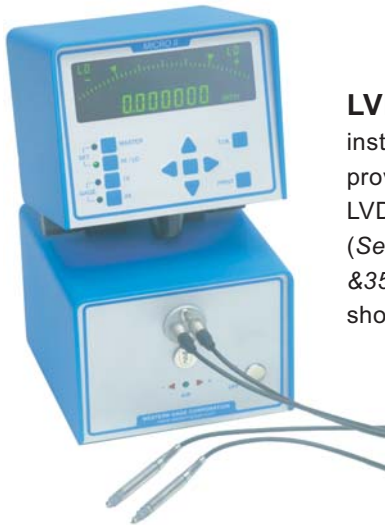

LVDT Readouts -- Factory installed interface modules provide the capability to operate LVDT type inductive probes. (See *LVDT probes on pages 34 & 35*). **Model AEQ 42-11-E2** is shown at left.

Micro IIi Readouts incorporate backlit LCD displays that flag out-of-tolerance conditions by changing color from green to red. Seven decade digital displays show actual feature sizes or deviations from nominal sizes. They also include analog bargraphs to graphically display the test piece condition relative to the product limits. Auto-Zero and Auto-span setting features make these instruments very operator friendly. USB & RS-232C serial data and process control outputs are standard.

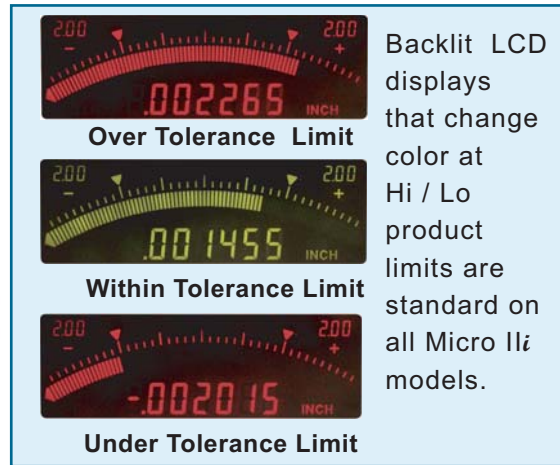

Multiple inputs with single display -- Auto-select models direct multiple inputs to a single display. As gages are sequentially inserted in the workpiece, the readout automatically senses the active gaging member and displays the reading. Up to four air gages or pairs of LVDT inputs can be connected to a single display. **Micro IIi model AEQ 42-14A-60** is shown above right.

MULTI-CHANNEL MICRO II_i READOUTS

Multi-channel Micro II_i readouts come with up to four input channels which can be configured for operation with either dimensional air gages or LVDT electronic gaging cartridges.

Dual Input Micro II_i models with three displays provide fast, accurate inspection of the internal and external diameters of mating parts. The upper display shows the I.D. size, the middle display shows O.D. size, and the lower display shows the calculated clearance between the parts.



Model AEQ-42-32N-60 connected to an air probe and air ring gage with guide chute is shown above. See *Guide Chutes* on page 23.

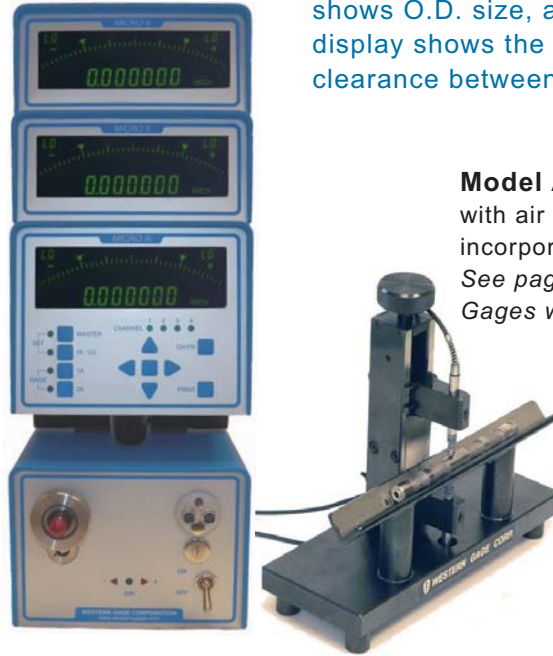

Model AEQ-42-32N-60-E2 with air probe and vee gage incorporating LVDT probes. See page 34 for more on *Vee Gages with Guide Chutes*.

Micro II_i Readout order Codes:

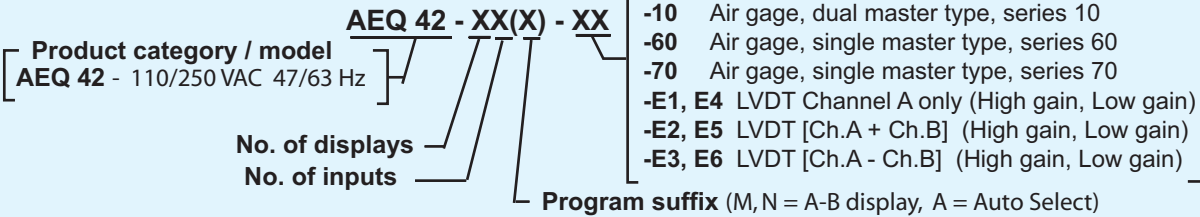

Micro II_i Configurations:

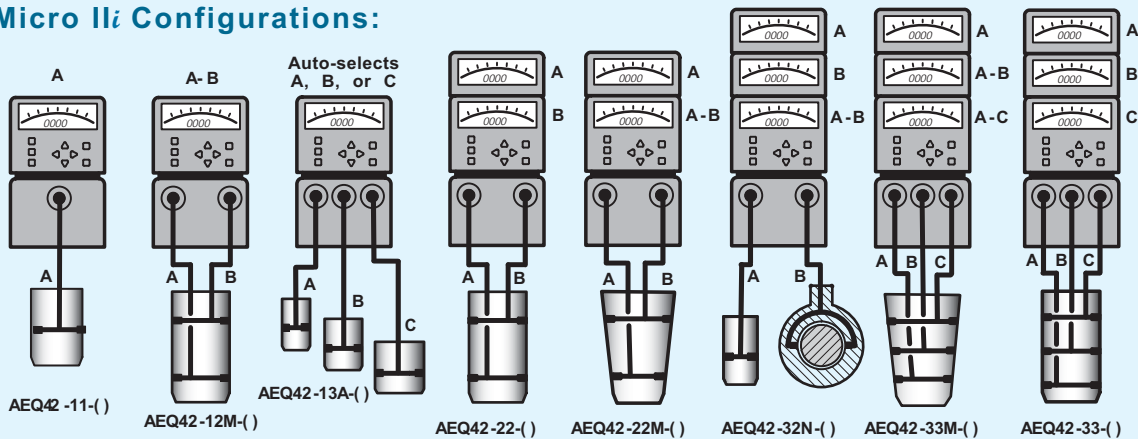

See next page for *Micro II_i* specifications

Taper Gaging applications using Micro II_i Readouts -- see page 28

MICRO II_i READOUT TECHNICAL DATA

Digital display:

Red-green backlit, 7 decade, LCD shows actual part sizes. Digital resolutions are set according to the Hi & Lo product limit span -- see table at bottom of page.

Bargraph display:

Red-green backlit, 81 segment bargraph graphically displays the workpiece size and acceptance limits.

Out-of-tolerance Indicators:

O/T conditions are flagged by changing the displays from green to red.

Auto-Zero feature: (single master)

Micro II_i readouts configured for single master operation have their sensitivities set at the factory using master standards. These instruments are zeroed by the user placing a setting master on the gage and pressing the center key to Auto-Zero the readout.

Auto-Span feature: (dual master)

Users set the sensitivity and zero on Micro II_i readouts configured for dual master operation using Min & Max setting masters. Pressing the center key starts the Auto-Span setting cycle with prompts for the user to sequentially place the setting masters on the gaging member; the sensitivity and zero are set automatically.

Features, front panel:

Gage 1X -- Sets Hi/Lo limits at 50% of full scale.

Gage 2X -- Sets Hi/Lo limits at 25% of full scale.

Hi/Lo -- Inputs product acceptance limits.

Master -- Inputs master sizes.

Print button -- Transmits serial data output.

T.I.R. / CH mode button -- Activates T.I.R. mode on single channel readouts, indexes active channel on multi-channel readouts.

Arrow key array -- Navigates set-up data, and activates Auto-Zero & Auto-Calibration cycles.

Pneumatic Zero adjust (On air gage modules only)

Air Status indicator -- indicates correct air pressure.

Gage inputs: specify from 1 to 4 input modules per enclosure

Air gage, series 10 -- all dual master types.

Air gage, series 60,70 or 80 -- single master types:

LVDT Input, high gain -- ranges $< \pm .003"$ (.076mm)

LVDT Input, low gain -- gaging ranges $> \pm .0015"$

Extended LVDT ranges, consult factory. (.038mm)

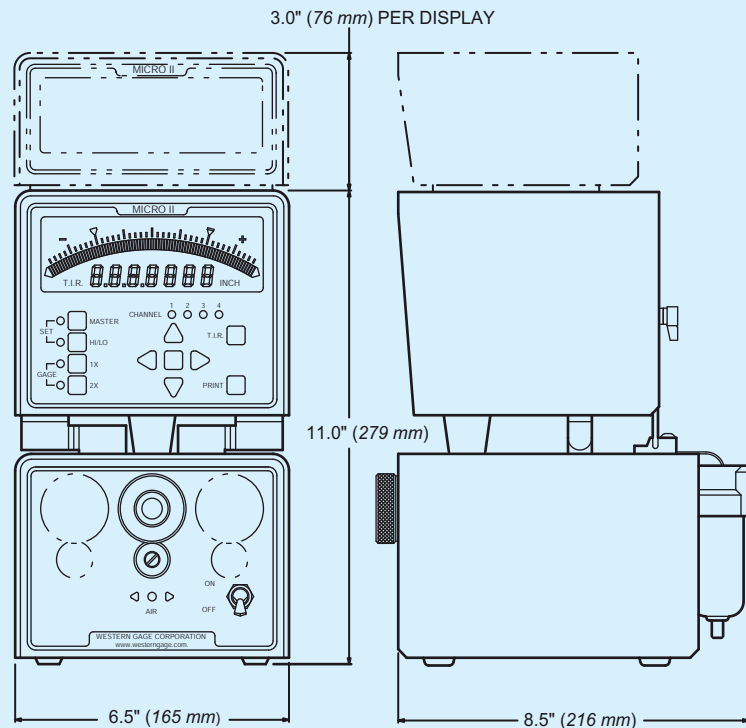

Features, rear panel:

Polarity of input channels (Slide switch).

Inch or metric unit selection (Slide switch).

Printer configuration (Slide switch).

Operator front panel lockout (Slide switch).

Outputs, rear panel:

Digital -- RS-232C serial port (9 pin Sub-D male) & **USB type B** outputs digital display readings.

I/O Process control -- (9 pin Sub-D female) Commands print data, T.I.R. mode; outputs: over/under tolerance conditions (TTL 2 ma. max.).

Power required: (Not field selectable)

100/240 VAC 50 - 60 Hz (Order Code AEQ-42-XX-XX)

Weight: Single channel unit: - 12 Lbs (5.5 Kg)

+ 2 Lbs (.9 Kg) / additional channel

Air gage module requirements:

.5 to 2 SCFM @ 40 to 150 psi (The actual air flow depends on nozzle sizes and gaging ranges of the air gage members connected to the readout).

Digital Display Resolutions (default settings)

Min-max range	Digital Resolution
less than .00021" (.0053 mm)	.000002" (.00005 mm)
less than .0011" (.028 mm)	.000005" (.0001 mm)
less than .0021" (.053 mm)	.00001" (.0005 mm)
less than .0301" (.765 mm)	.00005" (.001 mm)

See page 9 for Micro II_i order codes

AIR-ELECTRIC CONVERTERS for COMPUTER GAGE STATIONS



Model AEK II Air-Electric converters coupled with GageChek Readouts or PC Computer Gage Stations provide more computing capacity than Micro Ili readouts. These converters use the same proven air gage interface modules as the Micro Ili and MilliCheck Readouts. Each converter unit accommodates up to four analog and serial digital outputs in one shop hardened housing. Multiple AEK converters can be stacked to accommodate complex applications.

Air-Electric converter model AEK 30-4-60 .

AEK II Air-Electric converter technical data

Gage inputs: Specify from 1 to 4 Air gage or LVDT modules per enclosure. (Modules are the same as for Micro Ili readouts).

Analog outputs: Up to four, ± 10 VDC full scale outputs, (1.0 ma. max.) on 9 pin Sub-D female connector.

Digital output: Serial RS-232C, continuously outputs the analog voltage values for each channel, 10 updates per second.

Uses: Carriage return and line feed delimiters,
Data bits: 8, Baud rate: 9600.
(9 pin Sub-D male connector).

Controls, front panel:

- Channel select
- Zero adjust
- Span adjust (dual master only)
- Pneumatic Zero adjust (A/G modules only)

Controls, rear panel:

- Channel gain adjust lockouts
- Zero adjust lockout (global)
- Serial output rate

Air gage module requirements:

.5 to 2 SCFM @ 40 to 125 psi (The actual air flow depends on nozzle sizes and gaging ranges of the air gage members connected to the readout).

AEK II Air-Electric order codes:

AEK 30 - X - XX - (*)

Product category / model Gage interface

Number of channels

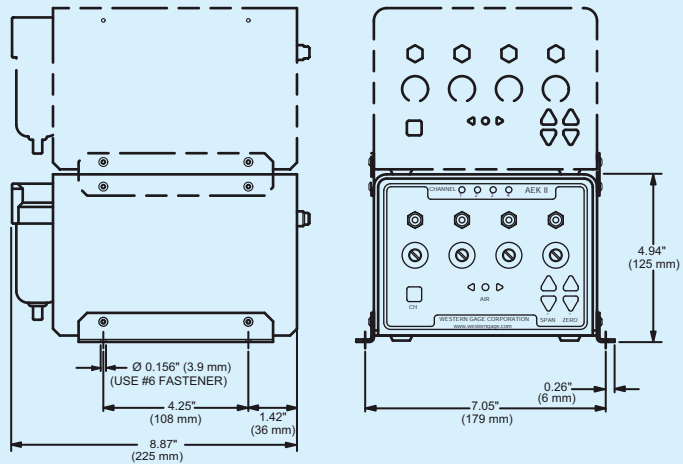

Weight: 7 Lbs (3.2 Kg)

Power:

User supplied: 9 - 30 VDC, 300 ma. when used with 4 air modules (600 ma. with 4 LVDT modules); requires 5.5/2.1 mm female plug (Digkey/CUI Inc #PP-002A or equivalent).

Or use WGC power supplies:

PSR-30, 110-120 VAC 60 Hz (USA)

PSR-31 Universal Power supply 100-240 VAC 50-60 Hz
(Includes plug adapters for North America, Australia, U.K., Europe).

Code	Description
-10	Air gage, dual master type, series 10
-60	Air gage, single master type, series 60
-70	Air gage, single master type, series 70
-E1, E4	LVDT Channel A only (High gain, Low gain)
-E2, E5	LVDT [Ch.A + Ch.B] (High gain, Low gain)
-E3, E6	LVDT [Ch.A - Ch.B] (High gain, Low gain)

* Show module dash numbers in order of installation, if all are the same, show one only.

GAGE-CHEK READOUTS



Gage-Chek model MGC-(XX)

GageChek Readouts feature multi-channel inputs and programmable multi-color displays. They accept up to eight air gage inputs from Western's model AEK II Air/Electric converters, or eight LVDT sensor inputs or combinations of both. SPC analysis from an integrated database is included with connectivity to PCs and other peripherals thru RS-232 serial, Digital I/O and USB ports. I/O ports include two relay outputs for automated process control.

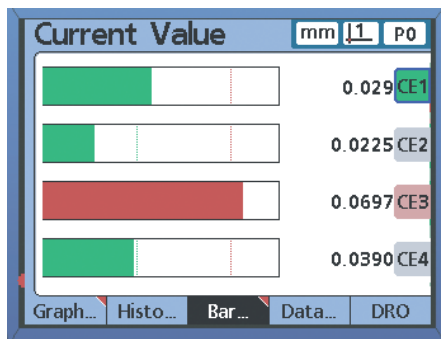

Gage-Chek displays multiple inputs, utilizing user defined mathematical formulas, logic functions and selectable display colors.



Multi-Channel Air Gage application using Gage-Chek with AEK II Air/Electric Converters and six channel air spindle inspects bore for roundness, straightness and size.

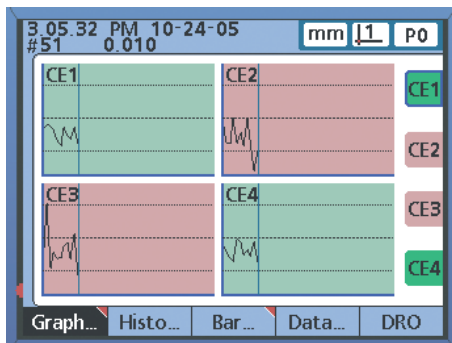

SPC capabilities include analysis of stored data, outputs to printer and data loggers.

Order Codes	
Model	Inputs
MGC-A1-(XX)*	Single analog channel
MGC-A4-(XX)	4 analog channels
MGC-A8-(XX)	8 analog channels
MGC-D4-(XX)	4 digital channels (RS-232)
MGC-D8-(XX)**	8 digital channels (RS-232)
MGC-L4-(XX)	4 LVDT channels
MGC-L8-(XX)	8 LVDT channels

* (XX) - Custom Program ID
 ** Serial RS-232 data output is not available on this model*

COMPUTER GAGE STATIONS

Industrial Computer with 10 Circuit Air Spindle.

Checks size, roundness and concentricities of crankshaft bearing bores in V-8 Engine casting.

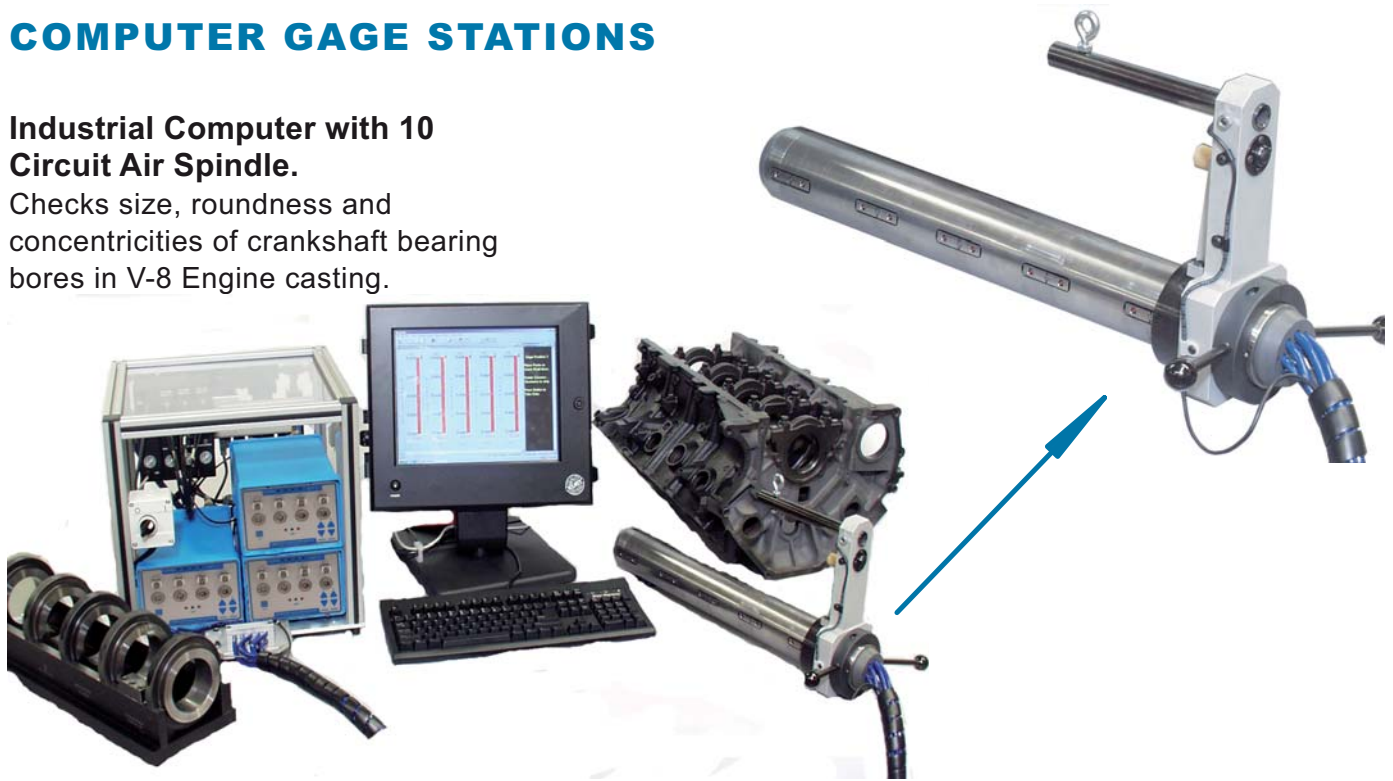

P.C. Computer Gaging Stations

CWK-2 Industrial computer

IBM PC compatible computer with LCD Monitor. Communication ports: 1 Ethernet card, Parallel, Serial, and USB ports. Includes SPC software programs supporting variables and attributes charting and full statistical reporting. Check factory for detailed specifications on this item.

CWK-USB Base module

Base USB module, interfaces input modules with gage station computer. Connects directly with PC through USB cable and supplies power to other modules from a 110/220 VAC 50/60 Hz outlet.

CWK-AL4 Analog module

Quad Analog module, reads four channels of analog signals per module. Configured for ± 10 VDC, other ranges optional. Includes foot switch input. Uses Hirose HR 10A-7R-6S Connectors.



CWK-LV4 LVDT module

Quad LVDT module, drives four LVDT or Half bridge gaging cartridges. Has 127 software configurable gain settings per channel. Includes foot switch input. Uses Hirose HR 10A-7R-6S Connectors.

CWK-IO Digital I/O module

Digital Input/Output module. Sixteen inputs & outputs per module. Inputs: 12-24 VDC, auto sourcing or sinking. Outputs: sinking 1 ampere max. Uses 37 pin d-Sub female connector.

READOUT ACCESSORIES

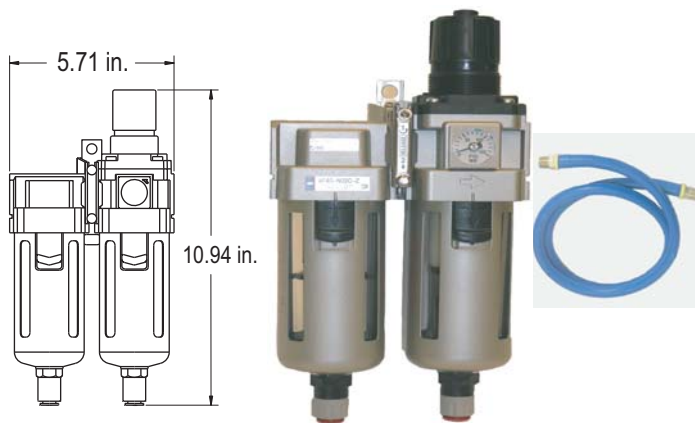

Production Filter & Regulator assembly

Highly recommended for all air gage readouts unless supply air is already conditioned with high quality oil and water removal equipment. The AFR-12 filter assembly contains a 50 μ prefilter, factory preset regulator, and a submicron coalescing filter with automatic bowl dump. Input 85 to 150 psi, output regulated to 80 psi. One filter assembly will handle two readouts with 4 air channels each. 1/4-NPT connections, supplied with 3.3 ft (1 m) hose.

Order code **AFR-12**



Mini Filter supplied on MilliCheck, Micro II*i* and AEK readouts. Clear plastic bowl with five micron element, 1.1 oz. fluid capacity with automatic drain.

Order code **AFA-1**
(Filter element only . . . **AFA-3**)



Air Input Hose .25" I.D. x .50" O.D rubber air supply hose with 1/4 NPT male connections. Use dash number to indicate hose length.

Order code: **ASH-1-** [hose lg. (ft.)]



Mini-Printer provides inexpensive data logging capability for Micro-Air Readouts. The IMP-24 printer uses standard adding machine paper. Black ribbon cartridges are easily replaceable. The Mini-Printer comes complete with serial communication cable and power supply.

Order code, Micro Air I **IMP24-1**
Order code, Micro Air II & II*i* . **IMP24-2**

Mini-Printer Accessories pack

Contains 1 ea. replacement ribbon cartridge and 3 rolls of paper. (Not shown)

Order code . . . **IMP-24-3**

Foot switches for commanding Print and T.I.R functions on Micro II Readouts. Attach suffix P or T to indicate Print or TIR interface. (They may also be used with P.C. Workstations, check with factory for compatible connectors). Heavy duty model is recommended for shop floor usage.



AFS-2-(P,T) General use footswitch



AFS-5-(P, T) Heavy Duty Footswitch

Serial interface cable

4 ft. with 9 pin Sub-d female-female connectors. Use on Micro II*i* to PC serial ports, and AEK serial port to the GageChek secondary serial port.

Order code **PCC-9**

Null modem cable

Same as PCC-9 except the input/output lines are cross-over wired. Use on AEK serial port to GageChek primary serial port.

Order code **PCC-9N**



PCC-9, PCC-9N

READOUT ACCESSORIES

AEK Analog Interface cables Connect AEK air/electric converters to GageChek or CWK Gage station analog input ports; Sub-d, 9 pin male connector splits to 1 to 4 lines with DIN or Hirose connectors, 4 foot long. Add dash number to order code to specify number of lines.

Order codes:

DIN connectors . . . **WGC14363-[(No. of lines)]**
(For use with GageChek's analog inputs)

Hirose connectors **WGC14530-[(No. of lines)]**
(For use with Kurt analog modules)



WGC14363- 4



WGC14530- 2

Power Supplies for MilliCheck & AEK Readouts:

PSR-30 Standard power supply for North America 105 - 125 VAC, 60 Hz. (Included with MilliCheck Readouts).

PSR-31 Universal supply, 100 - 240 VAC 47-63 Hz. Includes adapter kit for (North America, UK, EURO, & AUST.).



PSR-30



PSR-31

Toggle Valve Manifold

connects to front of Air Gage Readouts, allowing the use of multiple air gage members on the same readout without the fuss of disconnecting and reconnecting hoses. Manifolds are available in up to 9 stations. Support legs are standard on manifolds with 4 or more stations.

Order code:

AMD-[x][x][x]
 Number of stations Toggle Valve
 T yes
 N No

Readout connection
 W Western Gage
 F Mahr-Federal
 S .50 Ø Shank
 C Hose w/flare fitting

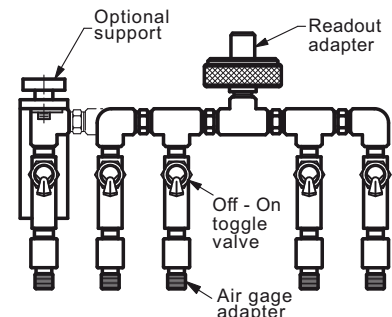
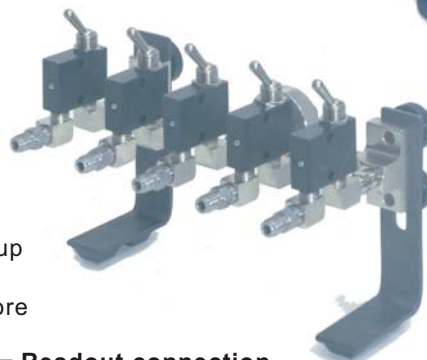

Air Gage Positioner

Model ABS-() Lift Stand with lever actuator positions air probes and air ring gages at multiple inspection locations. Includes adjustable limit stops, detents and chuck for gaging members. Models cover stroke ranges up to 2.10". Applications include inspection of bearing races, valve sleeve & spools, fuel injector components.

Order code: Consult factory for details.



USB Converter

Model PCU-1 Converter connects serial outputs on Micro II or AEK to USB ports. Allows communication from Western Gage readouts to computers equipped with a type A USB port. 6 ft. cable length. Comes with driver for Windows 98 and higher, and gender changer model PCG-1

Order code: PCU-1

See pages 19 & 21 for handles, hoses and fittings for air gage members.

Air Probes for Checking Internal Diameters

Air probes are also referred to as air plug gages or air spindles by some manufacturers.

Air probes with body diameters from .044"(1.1 mm) to 6.26"(160 mm) are supplied from Western's stock of semi-finished gages. Review the selection criteria on this page and see pages 18 & 20 for dimensional data.

Air probe styles



Blind style Air Probes have the sensing nozzles near the front end.



Thru-hole style Air Probes have the sensing nozzle set back from the end, which provides maximum wear life.



Small Air Probes may require an extension added at the factory to reach into deep holes.



Tubular handles are standard on large Series 60 to 80 Air Probes (single master types).



Miniature air probes work well on closely toleranced holes. They are available as dual master types only.



Custom Air Gages with Slot Jets can inspect smaller features than those inspected with round jets. 2.78 mm diameter air probe with .30 mm wide slot is shown above.

Air Probe features

The illustration below shows the construction of a typical air probe. The probe comprises a hardened steel body in which air passages are drilled to two or more gaging nozzles. The body is precision ground to slip into the bore at the low limit of the product tolerance; note the nozzle tips are recessed a small amount below the probe body as shown in the magnified view of the air gage nozzle.

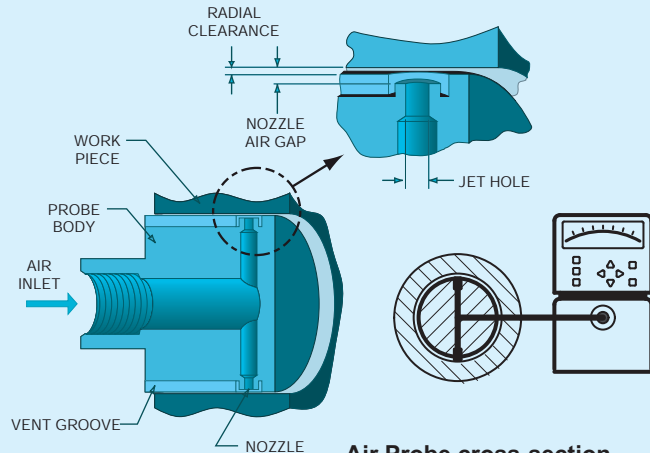

Air Probe cross-section

By recessing the air nozzles below the probe body, the measurement is made non-contact so that wear does not directly affect the accuracy of the gage. The air flow purges the gaging surface of contaminants thus making air gage measurements highly repeatable. The probes opposed nozzle design creates a "differential" type of measurement that is independent of how the probe is positioned radially within the test bore -- *i.e.* radial movement causing an increase in air flow in one nozzle is offset by a corresponding decrease in flow in the opposing nozzle. These features are key factors in attaining fast, accurate gaging with unskilled operators.

Application considerations -- When selecting an air probe, the jet locations should be selected bearing in mind that the measurement occurs where the air exits the gaging nozzle. The air jet must be completely covered by the workpiece plus some additional margin -- consider a land width that's twice the jet hole diameter to be the minimum required for satisfactory gaging. Also note that the probe will not measure closer to the hole bottom than the leading edge of the jet hole. Specifying a super blind style will allow measurement closer to the bottom; but be aware that the nose end of the probe wears more rapidly than the rest of the body so the best gage life is obtained with thru-hole style probes.

AIR RINGS and C-GAGES for EXTERNAL DIAMETERS

Single master vs Dual master systems

Accurate dimensional measurement requires readouts and gaging members that are calibrated with known standards. Both single and dual master methods of calibration are widely used for air gage systems. The selection of one over the other involves trading off the flexibility and accuracy of the dual master system versus the ease of set up and economy of using the single master system. Properly applied, both systems provide acceptable levels of accuracy.

The dual master system user calibrates the readout by observing that the span displayed by the readout corresponds to the span between the minimum and maximum setting masters. This method sets the combined sensitivity of all the components of the gaging system at one time. The sensitivities of components such as flow restrictors, amplifiers, pressure indicators and gaging nozzles, as well as pressure drops in air lines, are included in one overall calibration; thus stringent control of individual components is not necessary to obtain accurate overall results using a dual master system.

The single master system requires controlling the sensitivities of both the gage readout and the air gage member at the factory prior to shipment. The sensitivity of the air gage readout is verified using master orifices that simulate air flow to the gage nozzles and the gaging member sensitivity is controlled by precise finishing of the gaging nozzles with verification using factory setting masters. Ease of set up is the principal advantage of readouts configured for single master operation, though significant cost savings may also be obtained in large gage sizes by eliminating the cost of a second master.

Single master system accuracy. An allowance must be made for possible scaling errors in both the comparator and the gaging member of the single master system. The effect of scaling error increases in direct proportion to the span between the master and the point of measurement. For instance, if a measurement is made .0002" from the mastered dimension, a scale factor error of 5% would cause an error of 5% of the .0002" span or .000010"; if the span were extended to .001", this error would become .000050". An error allowance of 5% is a reasonable assumption considering that inaccuracies of manufacture and stability with age must be allowed for in both the gaging member and the comparator. For most applications, this is an acceptable level of accuracy. Users should be aware, however, that the use of a master that is well outside of the tolerance zone may lead to unacceptable errors in some applications.

Air Ring Gages

Air Ring styles Center-jet style air rings have gaging nozzles near the center of the body. Shoulder-jet style have jets near the leading edge of the bore. For both air rings and air probes, the best wear life is obtained by using thru-hole or center-jet styles when the application permits.



Shoulder type 3-Jet Air Ring



Center Jet type 2-Jet Air Ring

2 & 3 Jet Air Rings Air ring gages are often made with more than two interconnected air nozzles. Three-jet air rings are commonly specified when centerless ground parts are to be inspected. They will detect three lobe out-of-round conditions prevalent in centerless ground parts that are not detectable with two-point gaging methods (see illustration below). Adding additional jets provides direct display of average diameters.

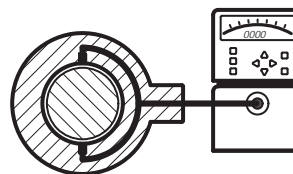

2 Jet Air Ring

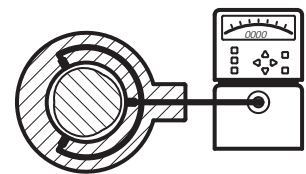

3 Jet Air Ring

Air C-Gages

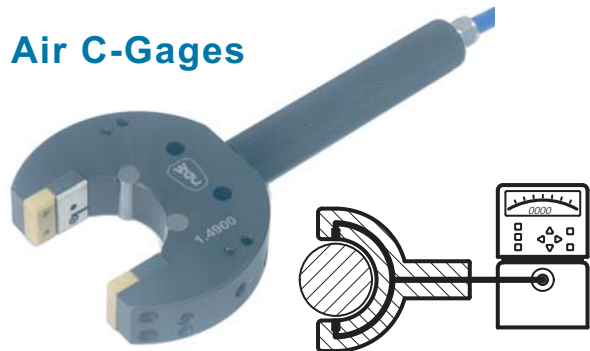

Air C-Gages provide side access making them a convenient means to measure shaft O.D.'s while the workpiece is mounted on a grinder. Western's C-Gages feature carbide back stops and Kevlar reinforced nylon bumpers that prevent marking parts.

See pages 22 & 23 for specifications and order codes for Air Ring Gages, C-Gages & Accessories

Air Probe Dimensional Data - Dual Master - Series 10 - 50

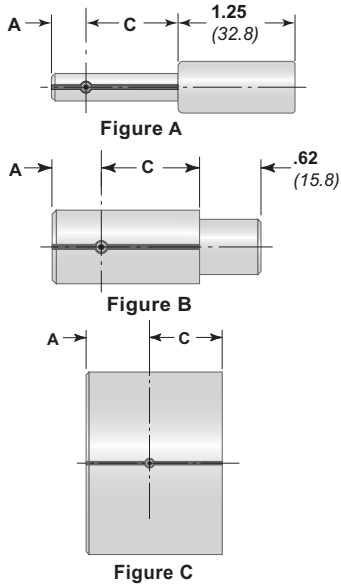

Body clearances

Clearances for series 10 thru 50 air gage members are referenced to the maximum material condition of the feature to be inspected. Determine the body size of an air probe by subtracting the clearance value shown in the adjacent table from the minimum part size. For air ring gages, add the value shown to the maximum part size.

Clearance recommendations

Low clearance . . Class 1 -- for the highest accuracy applications such as select fitting of valve spools and sleeves where finishing tolerance is less than .00016" (4.1 µm).

Standard clearance . . Class 2 -- best for most applications. Members are furnished to this specification when no other specification is given.

Extra clearance . . Class 3 -- for applications requiring extra gaging range such as grinding and honing operations where sizing information is required before the final size is obtained.

Sample order code for Dual master air probes

APT-12-C-.5000/.5005

member type
series spec.
clearance spec.

(Air Probe Thru - Spec 12 - Chrome - Range)

AIR PROBE DIMENSIONAL DATA, Series 10, 40, & 50

Air probe body dimensions (inches / millimeters):

Size above -incl.	Dimension A			Dim. C	Fitting	Figure
	APT	APB	APS			
.059 - .073 1.50 - 1.85	.190 4.83	.080 2.03	.050 1.27	.625 15.88	#10-32 UNF	A
.073 - .120 1.85 - 3.05	.190 4.83	.080 2.03	.050 1.27	.625 15.88	#10-32 UNF	A
.120 - .183 3.05 - 4.65	.250 6.35	.085 2.16	.065 1.65	.750 19.05	.25-28 UNF	A
.183 - .300 4.65 - 7.62	.375 9.53	.095 2.41	.075 1.91	1.000 25.40	.25-28 UNF	A
.300 - .485 7.62 - 12.32	.440 11.18	.095 2.41	.075 1.91	1.000 25.40	#10-32 UNF	B
.485 - .860 12.32 - 21.84	.500 12.70	.095 2.41	.075 1.91	1.000 25.40	.25-28 UNF	B
.860 - 2.510 21.84 - 63.75	.750 19.05	.095 2.41	.075 1.91	1.000 25.40	.50-20 UNF	B
2.510 - 5.865 63.75 - 148.97	.875 22.23	.105 2.67	.085 2.16	1.000 25.40	.50-20 UNF	C
5.865 - 8.260 148.97 - 209.80	1.062 26.97	.125 3.17	.105 2.67	1.000 25.40	.50-20 UNF	C

Air probe body clearances (inches / millimeters):

Size above - incl.	Clearance class		
	1	2	3
.059 - .120 1.50 - 3.05	.00015 3.81	.0003 7.62	.0006 15.24
.120 - .183 3.05 - 4.65	.00015 3.81	.0004 10.16	.0008 20.32
.183 - .540 4.65 - 13.72	.0002 5.08	.0005 12.70	.0010 25.40
.540 - 1.510 13.72 - 38.35	.0003 7.62	.0006 15.24	.0012 30.48
1.510 - 3.010 38.35 - 76.45	.0004 10.16	.0008 20.32	.0014 35.56
3.010 - 4.510 76.45 - 114.55	.0005 12.62	.0009 22.86	.0018 45.72
4.510 - 6.510 114.55 - 165.40	.0007 17.78	.0012 30.48	.0022 55.88

Standard jet diameters (inches / millimeters):

Size above-incl.	Series #	
	10 & 50	40
.059 - .073 1.50 - .185	.018" .046	NA NA
.073 - .120 .185 - 3.05	.023" .058	NA NA
.120 - .183 3.05 - 4.65	.042" 1.07	NA NA
.183 - .323 4.65 - 8.20	.047" 1.19	NA NA
.323 - 9.26 8.20 - 235.4	.050" 1.27	.078" 1.98

See pages 26 & 27 for more detail on specifying air probes

Accessories for Air Probe - Dual Master - Series 10 thru 50

AIR GAGE SIZE ABOVE-INCL	DASH NO.	THREAD SIZE	HANDLE Dia. H	(EXTENSION DIMENSIONS)			(EXTENSION PART NO.S)	
				Dia. S	L	P	DIM E = 4 in.	DIM E = 6 in.
.059-.120	-3	#10-32 UNF	.287"	.312"	1.62"	.38"	AHE-34	AHE-36
.120-.300	-4	.25-28 UNF	.437"	.437"	1.62"	.38"	AHE-44	AHE-46
.300-.485	-3	#10-32 UNF	.287"	.312"	1.62"	.38"	AHE-34	AHE-36
.485-.860	-4	.25-28 UNF	.437"	.437"	1.62"	.38"	AHE-44	AHE-46
.860-UP	-8	.50-20 UNF	.812"	.750"	1.75"	.25"	AHE-84	AHE-86

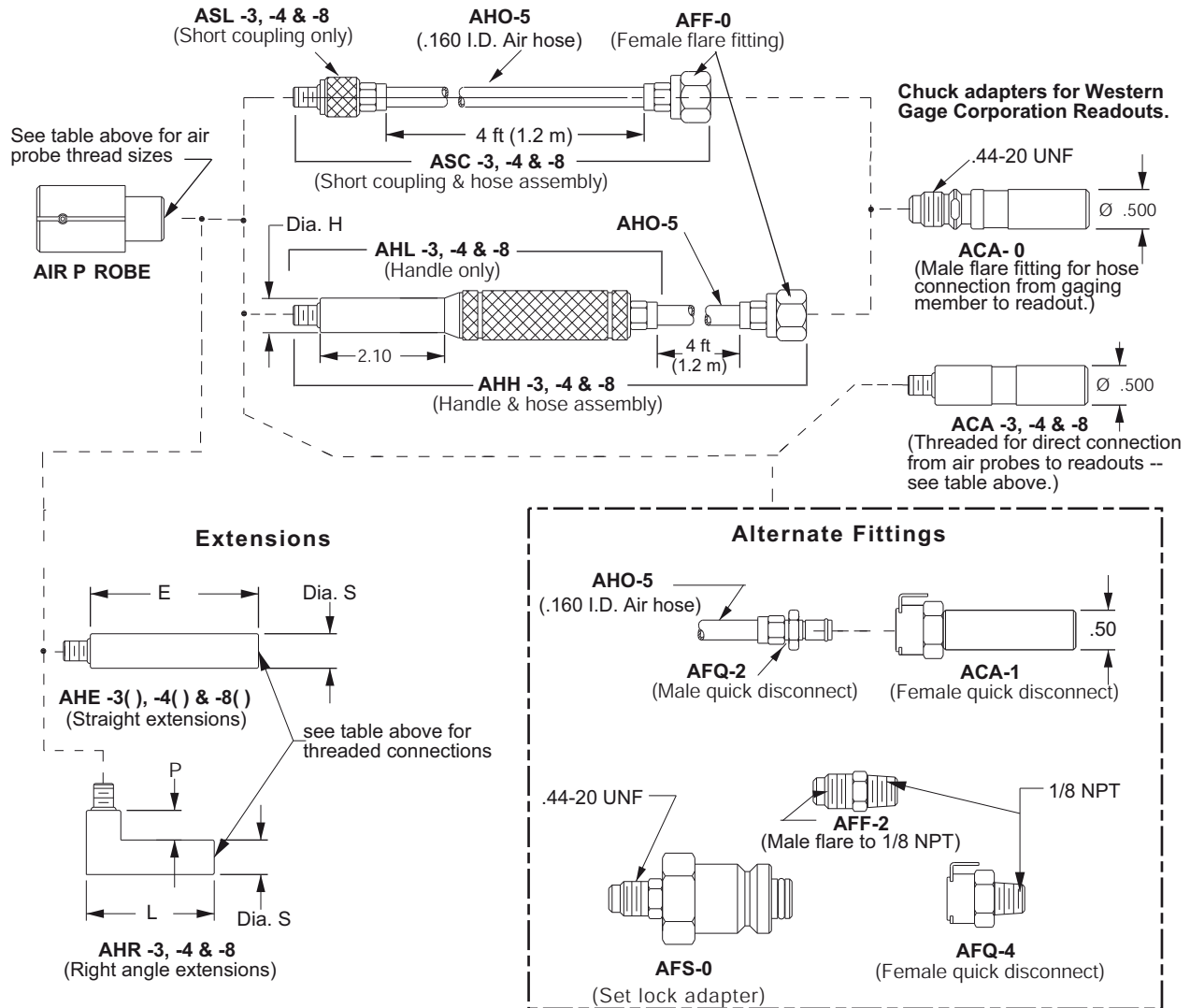

AIR PROBE ACCESSORIES, SERIES 10 THRU 50

AHH-3	Handle & hose -#10-32 UNF	AHE-34	Extension, 4 in. - #10-32 UNF	ACA-4	Chuck adapter -- .25-28 UNF
AHH-4	Handle & hose -.25-28 UNF	AHE-36	Extension, 6 in. - #10-32 UNF	ACA-8	Chuck adapter -- .50-20 UNF
AHH-8	Handle & hose -.50-20 UNF	AHE-44	Extension, 4 in. - .25-28 UNF	ACA-9	Chuck adapter, male flare w/bleed
AHL-3	Handle only --- #10-32 UNF	AHE-46	Extension, 6 in. - .25-28 UNF	AFS-0	Set lock adapter, male flare
AHL-4	Handle only --- .25-28 UNF	AHE-84	Extension, 4 in. - .50-20 UNF	AFF-2	Male flare -- 1/8 NPT
AHL-8	Handle only --- .50-20 UNF	AHE-86	Extension, 6 in. - .50-20 UNF	REPAIR PARTS	
ASC-3	Short coupl'g & hose -#10-32 UNF	AHR-3	Rt. Angle adapter-#10-32 UNF	AHO-4	.125 Air hose only
ASC-4	Short coupl'g & hose -.25-28 UNF	AHR-4	Rt. Angle adapter-.25-28 UNF	AHO-5	.160 Air hose only
ASC-8	Short coupl'g & hose -.50-20 UNF	AHR-8	Rt. Angle adapter-.50-20 UNF	AFF-0	Female flare - .160 hose barb
ASL-3	Short coupling only -- #10-32 UNF	COMPARATOR FITTINGS		AOR-3	O-rings for -3 accessories, 10 pcs
ASL-4	Short coupling only -- .25-28 UNF	ACA-0	Chuck adapter -- male flare	AOR-4	O-rings for -4 accessories, 10 pcs
ASL-8	Short coupling only -- .50-20 UNF	ACA-1	Chuck adapter, quick disconnect	AOR-8	O-rings for -8 accessories, 10 pcs
		ACA-3	Chuck adapter -- #10-32 UNF	ACF-10	Chuck Nut & Brass Collet

Air Probe Dimensional Data-Single Master - series 60 - 80

AIR PROBE DIMENSIONAL DATA, Series 60, 70, & 80

Air probe body dimensions (inches / millimeters):

Size above -incl.	Dimension A			Dim. C	Figure	Available Series
	APT	APB	APS			
.059 - .073 1.50 - 1.85	.190 4.83	.080 2.03	.050 1.27	.625 15.88	A	70
.073 - .120 1.85 - 3.05	.190 4.83	.080 2.03	.050 1.27	.625 15.88	A	70
.120 - .183 3.05 - 4.65	.250 6.35	.085 2.16	.065 1.65	.750 19.05	A	60 & 70
.183 - .300 4.65 - 7.62	.375 9.53	.095 2.41	.075 1.91	1.000 25.40	A	60 & 70
.300 - .485 7.62 - 12.32	.440 11.18	.095 2.41	.075 1.91	1.000 25.40	A	60, 70 & 80
.485 - .860 12.32 - 21.84	.500 12.70	.095 2.41	.075 1.91	1.000 25.40	B	60, 70 & 80
.860 - 2.510 21.84 - 63.75	.750 19.05	.095 2.41	.075 1.91	1.000 25.40	B	60, 70 & 80
2.510 - 5.865 63.75 - 148.97	.875 22.23	.105 2.67	.085 2.16	1.000 25.40	C	60, 70 & 80
5.865 - 8.260 148.97 - 209.80	1.062 26.97	.125 3.17	.105 2.67	1.000 25.40	C	60 & 80

Air probe body clearances (inches / micrometers):

Size above -incl.	Clearance class				
	1	2	3	4	5
.059 - .120 1.50 - 3.05	.00015 3.81	.0003 7.62	.0004 10.16	----	----
.120 - .183 3.05 - 4.65	.00015 3.81	.0003 7.62	.0004 10.16	.0006 15.24	.0010 25.40
.183 - .246 4.65 - 6.25	.00015 3.81	.0003 7.62	.0005 12.70	.0008 20.32	.0018 45.72
.246 - .300 6.25 - 7.62	.0002 5.08	.0004 10.16	.0006 15.24	.0010 25.40	.0022 55.88
.300 - .485 7.62 - 12.32	.0002 5.08	.0004 10.16	.0006 15.24	.0012 30.48	.0026 66.04
.485 - .540 12.32 - 13.72	.0003 7.62	.0004 10.16	.0007 17.78	.0014 35.56	.0030 76.20
.540 - 1.510 13.72 - 38.35	.0003 7.62	.0004 10.16	.0008 20.32	.0016 40.64	.0030 76.20
1.510 - 3.010 38.35 - 76.45	----	.0005 12.70	.0009 22.86	.0018 45.72	.0030 76.20
3.010 - 4.510 76.45 - 114.55	----	.0006 15.24	.0010 25.40	.0020 50.80	.0030 76.20
4.510 - 6.510 114.55 - 165.40	----	----	.0012 30.48	.0022 55.88	.0034 86.36

Jet data & fittings:

Series	Jet dia.	Fitting
60	.048	.375-32 UNEF
70	.023	.281-40 UNS
80	.094	.375-32 UNEF

1 Ser. 60 not available in sizes below .120" (3.05mm).

2 Ser. 80 not available in sizes below .360" (9.14mm).

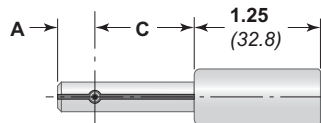

Figure A

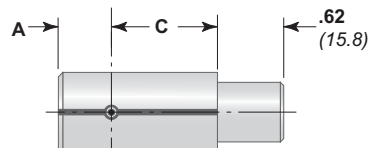

Figure B

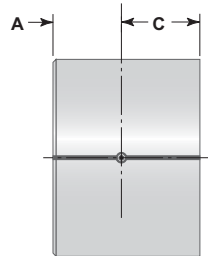

Figure C

Clearance recommendations Series 60 thru 80

Clearance values for single mastered gaging members are referenced to the nominal master sizes. Users should pick clearances that allow probes to enter the workpieces at their maximum material condition, and at the same time, not have excessive clearance at the minimum material condition.

To determine the body size of a single master air probe, subtract the clearance value shown from the nominal master ring. For air ring gages, add the value shown to the nominal setting master.

Guide lines for clearances are as follows:

Product tolerance	WGC specs.
.00001"-.00012" (.2μ - 3μm)	62, 71
.00012"-.0004" (3μ - 10μm)	63, 72
.0004" - .0020" (10μ - 50μm)	64, 73
.0020" - .0040" (50μ - 100μm)	65

Best accuracy will always be obtained with single mastered gages by mastering near the middle of the product tolerance.

Sample order code for Single master air probes

APB-64-S-.2495-XLC-3.00



(Air Probe Blind - Spec 64 - Steel - Range - Extra Long dim. C = 3.00")

See pages 26 & 27 for more detail on specifying air probes

Accessories for Air Probes - Single Master - series 60 thru 80

AIR GAGE SERIES	THREAD SIZE	Ø S	(HOSE ASSY PART NO.S)		(PROBE EXTENSION PART NO.S)		
			DIM H = 3 ft.	DIM H = 5 ft.	DIM E = 2 in.	DIM E = 4 in.	DIM E = 6 in.
60	.375-32 UNEF	.485"	AHA-63	AHA-65	AHL-62	AHL-64	AHL-66
70	.281-40 UNS	.360"	AHA-73	----	AHL-72	AHL-74	----
80	.375-32 UNEF	.485"	AHA-63	AHA-65	AHL-62	AHL-64	AHL-66

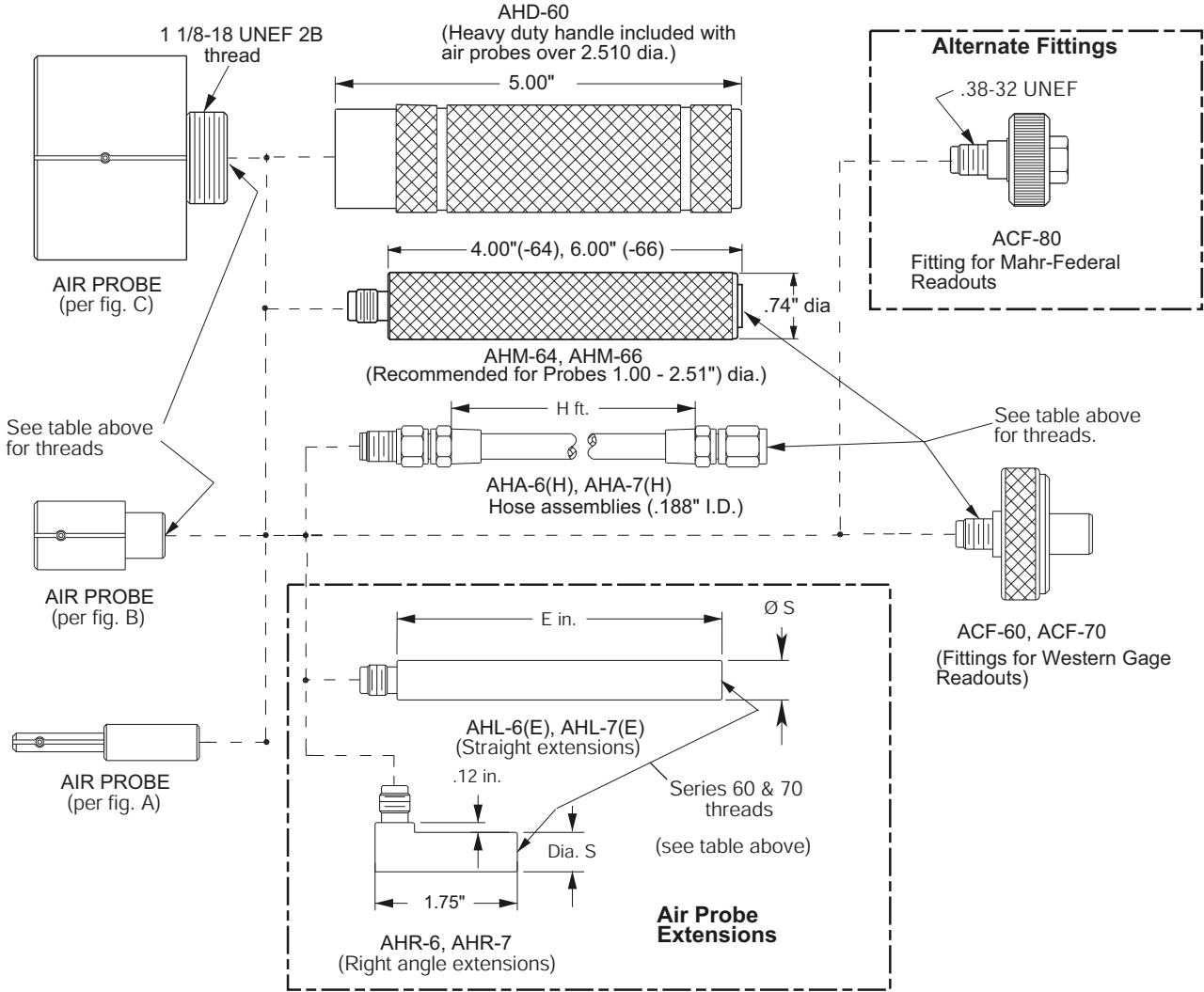

AIR PROBE ACCESSORIES SERIES 60 THRU 80

AHA-63	Hose ass'y, 3 ft -.375-32 UNEF	AHR-6	Rt. Angle adapter, .375-32 UNEF
AHA-65	Hose ass'y, 5 ft -.375-32 UNEF	AHR-7	Rt. Angle adapter, .281-40 UNS
AHA-66	Hose ass'y, 6 ft -.375-32 UNEF	REPAIR PARTS	
AHA-73	Hose ass'y, 3 ft -.281-40 UNS	AOR-10	O-ring kit for series 60, 10 pcs
AHL-62	Handle/ext., 2 in x .375-32 UNEF	AOR-07	O-ring kit for series 70, 10 pcs
AHL-64	Handle/ext., 4 in x .375-32 UNEF	READOUT FITTINGS	
AHL-66	Handle/ext., 6 in x .375-32 UNEF	ACF-60	Fitting, use on: Milli Check, Micro Air - Ser.60
AHL-72	Handle/ext., 2 in x .281-40 UNS	ACF-70	Fitting, use on: Milli Check, Micro Air - Ser.70
AHL-74	Handle/ext., 4 in x .281-40 UNS	ACF-80	Fitting, use on Mahr-Federal Readouts
AHD-60	Heavy duty handle 6" x Ø 1.20"		
AHM-64	Medium duty handle 4" x Ø .74"		
AHM-66	Medium duty handle 6" x Ø .74"		

Air Ring Gage Dimensional Data - Single & Dual Master

See page 27 for Air Ring Gage order codes

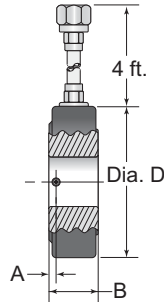

Series 10 - 50 (includes hose)

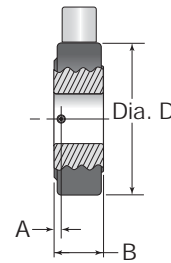

Series 60 - 80 (Order hose separately -- see pg 21)

Dual Master						
Air Ring Dimensional data, Series 10 thru 50						
Air ring gage body dimensions (inches / millimeters):						
Size	Dimension A			Dim. B	Dia. D	
above -incl	ARC	ARS	ARX	Dim. B	Dia. D	
.061 - .070*	.250	---	---	.500	1.73	
1.55 - 1.78	6.35	1.91	---	12.70	43.94	
.070 - .183	.281	.075	---	.562	1.73	
1.78 - 4.65	7.14	1.91	---	14.27	43.94	
.183 - .300	.281	.095	.080	.562	1.85	
4.65 - 7.62	7.14	2.41	2.03	14.27	46.99	
.300 - .760	.375	.095	.080	.750	2.31	
7.62 - 19.30	9.53	2.41	2.03	19.05	58.67	
.760 - 1.760	.500	.125	.085	1.000	3.31	
19.30 - 44.70	12.70	3.18	2.16	25.40	84.07	
1.760 - 3.010	.560	.125	.085	1.120	4.62	
44.70 - 76.45	14.22	3.18	2.16	28.45	117.35	
3.010 - 4.000	.625	.135	.090	1.250	5.87	
76.45 - 101.60	15.88	3.43	2.29	31.75	149.10	
4.000 - 4.875	.625	.135	.090	1.250	6.87	
101.60 - 123.83	15.88	3.43	2.29	31.75	174.50	
4.875 - 5.750	.625	.135	.090	1.250	7.87	
123.83 - 146.05	15.88	3.43	2.29	31.75	199.90	
5.750 - 6.625	.625	.135	.090	1.250	8.87	
146.05 - 168.28	15.88	3.43	2.29	31.75	225.50	
6.625 - 7.500	.625	.135	.090	1.250	9.87	
168.28 - 190.50	15.88	3.43	2.29	31.75	250.70	

Series 10, 40 & 50 fittings: Air ring gages are furnished with 4 ft (1.22 mm) hoses with .44-20 female flare fittings.

* Air ring sizes .061 to .183 are available in 3 jet, carbide only.

Single Master						
Air Ring Dimensional data, Series 60 thru 80						
Air ring gage body dimensions (inches / millimeters):						
Size	Dimension A			Dim. B	Dia. D	
above -incl	ARC	ARS	ARX	Dim. B	Dia. D	
.183 - .300	.281	.095	.080	.562	1.85	
4.65 - 7.62	7.14	2.41	2.03	14.27	46.99	
.300 - .760	.375	.095	.080	.750	2.31	
7.62 - 19.30	9.53	2.41	2.03	19.05	58.67	
.760 - 1.760	.500	.125	.085	1.000	3.31	
19.30 - 44.70	12.70	3.18	2.16	25.40	84.07	
1.760 - 3.010	.560	.125	.085	1.120	4.62	
44.70 - 76.45	14.22	3.18	2.16	28.45	117.35	
3.010 - 4.000	.625	.135	.090	1.250	5.87	
76.45 - 101.60	15.88	3.43	2.29	31.75	149.10	
4.000 - 4.875	.625	.135	.090	1.250	6.87	
101.60 - 123.83	15.88	3.43	2.29	31.75	174.50	
4.875 - 5.750	.625	.135	.090	1.250	7.87	
123.83 - 146.05	15.88	3.43	2.29	31.75	199.90	
5.750 - 6.625	.625	.135	.090	1.250	8.87	
146.05 - 168.28	15.88	3.43	2.29	31.75	225.50	
6.625 - 7.500	.625	.135	.090	1.250	9.87	
168.28 - 190.50	15.88	3.43	2.29	31.75	250.70	

Fittings:
 Series: 60 & 80 .375-32 UNEF fitting (order hose separately).
 Series: 70 .281-40 UNS fitting (order hose separately).

Air C-Gage Dimensional Data - Single & Dual Master

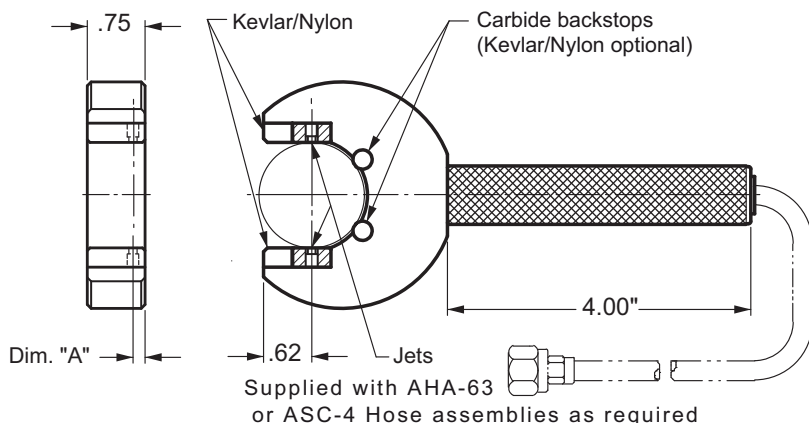

C-Gage Order Code:

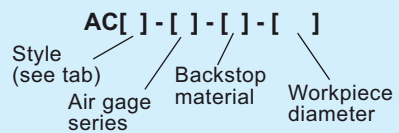

C-Gage type	Code	Dim. A
Shoulder Jet	ACS	.156 (4.0)
Center Jet	ACC	.375 (9.5)

C-Gages are available for O.D. sizes from .60" to 7.81" (15.2 - 198.3 mm).

Multi-channel C-Gages are available as custom designs.

Accessories for Air Ring Gages - Single & Dual Master

Base stands for air ring gages

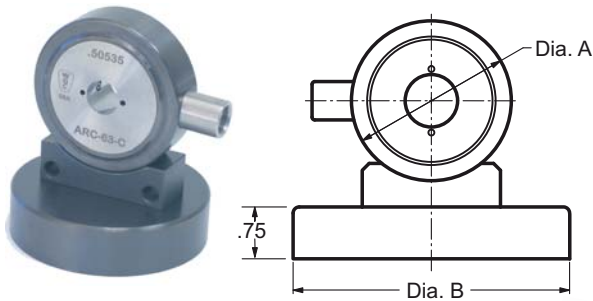

Order codes for base stands

Code	Range	Dia. A	Dia. B
ABA-0	.120 - .183 (.305 - 4.65 mm)	1.73"	2.94"
ABA-1	.183 - .300 (4.65 - 7.62 mm)	1.85	2.94
ABA-2	.300 - .760 (7.62 - 19.30 mm)	2.31	3.94
ABA-3	.760 - 1.760 (19.30 - 44.70 mm)	3.31	5.94
ABA-4	1.760 - 3.010 (44.70 - 76.45 mm)	4.63	5.94

Requires factory drilled mounting holes in the air ring housing.

Vee type Guide Chutes for air ring gages

Air Ring Gage Guide Chutes provide convenient means of gaging long parts with interrupted external diameters such as valve spools. Chutes can be ordered as single end or double end.

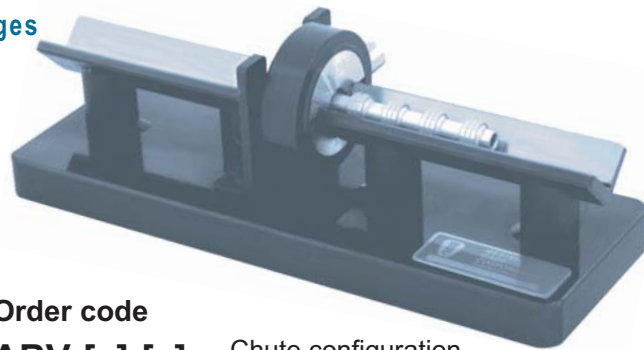

Dash No.	Gaging Range	Dimensions (inch)				
		A1	A2	B	C	D
-1	.183-300	5.66	8.00	3.00	2.00	1.09
-2	.300-760	6.74	10.00	3.50	3.00	1.60
-3	.760-1.760	7.87	12.00	4.00	3.50	2.46
-4	1.760-2.312	9.13	14.00	5.00	4.13	2.65

Requires factory modification of air ring housing.

Order code
ABV-[]-[]
 Chute configuration
 1 - Single End
 2 - Double End
 Dash no. →

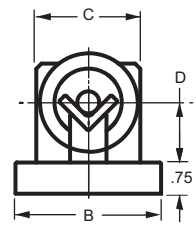
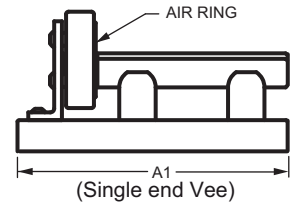
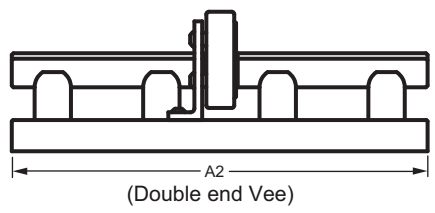

Guide pins & backstops

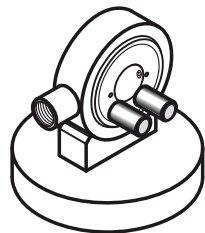

Guide pins can be added to an air ring gage to guide short parts. Consult factory for this modification.

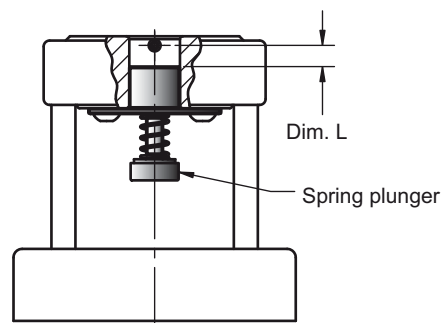
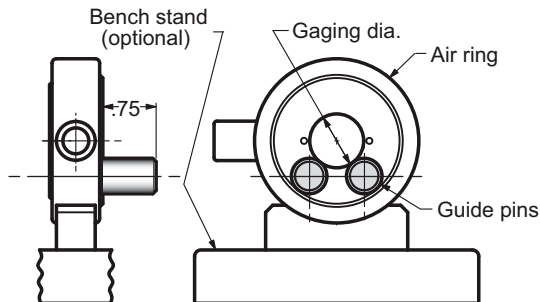

Plunger backstops facilitate inspection of short parts such as bearing races. Factory installation is required. Specify Dim. L when ordering the air ring gage. Base stand with standoffs is optional.

Setting Masters for Internal & External Diameters



Gage accuracy can be no better than the precision of the standards used for calibration.

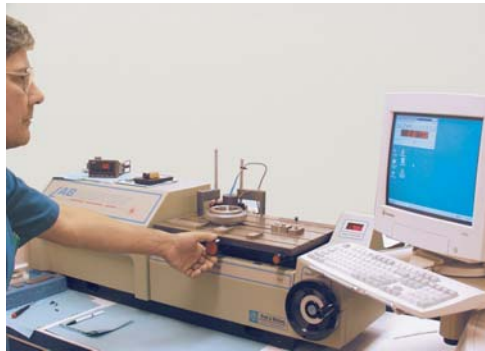

Western's master gages are fabricated from heat treated and stabilized chrome alloy steel blanks conforming to American Gage Design standard A.N.S.I. B47.1. After heat treat and stabilization cycles, these gages are custom finished by grinding and lapping to the precise dimensions specified. Final calibration is done in a temperature controlled gage calibration lab using electronic comparator instruments and laboratory grade reference standards.



Gaging accuracy. Good quality control practice calls for specification of masters with tolerances less than 10% of the workpiece tolerance (5% is considered ideal), and for periodic recalibration of the gage. Recalibration intervals are up to the user to establish depending on amount of usage, the accuracies required, and the calibration history of the gage. One year intervals are generally recommended as a starting point for moderate usages.



Inspection reports. Western Gage's setting masters are calibrated by transfer measurement with standards traceable to the National Institute of Standards and Technology (N.I.S.T.). Gage calibrations are done in Western Gage's temperature-controlled gage lab using test methods and equipment conforming to ISO/IEC 17025, ANSI/NCSL-Z540-1-1994. Long form Certificates of Calibration are supplied with all master gages.

REPORT OF CALIBRATION																																																											
WESTERN GAGE CORPORATION 3316-A Miya Linda Camarillo, California 93012 805-445-1410 Fax 805-445-7530					Customer: _____ Location: _____ Customer PO: _____ Report No: _____ Sales Order: _____																																																						
Instrument Used		4 Federal EHE-105					Deviation From Marker Size (µin) DATUM 0° AXIS 90° AXIS A _____ B _____ C _____																																																				
Instrument S/N		J83-B																																																									
Calibration Procedure		WGC-905																																																									
Applicable Standard		ANSI/ASME B89.1.6M, B89.1.5																																																									
Ref Block Set		990601			Ref Block Set Cal. Due 8/18/2011																																																						
<table border="1"> <thead> <tr> <th>TOOL NUMBER</th> <th>SIZE</th> <th>CLASS</th> <th>TOLERANCE</th> <th>STATUS</th> <th>W Dim</th> <th colspan="4">Deviation From Marker Size (µin)</th> </tr> <tr> <th></th> <th></th> <th></th> <th></th> <th></th> <th></th> <th>DATUM</th> <th>0° AXIS</th> <th>90° AXIS</th> <th></th> </tr> </thead> <tbody> <tr> <td></td> <td>1.0000</td> <td></td> <td></td> <td>New</td> <td>1.00</td> <td>A</td> <td></td> <td></td> <td></td> </tr> <tr> <td></td> <td>inches</td> <td></td> <td></td> <td></td> <td></td> <td>B</td> <td></td> <td></td> <td></td> </tr> <tr> <td></td> <td></td> <td></td> <td></td> <td></td> <td></td> <td>C</td> <td></td> <td></td> <td></td> </tr> </tbody> </table>										TOOL NUMBER	SIZE	CLASS	TOLERANCE	STATUS	W Dim	Deviation From Marker Size (µin)										DATUM	0° AXIS	90° AXIS			1.0000			New	1.00	A					inches					B										C			
TOOL NUMBER	SIZE	CLASS	TOLERANCE	STATUS	W Dim	Deviation From Marker Size (µin)																																																					
						DATUM	0° AXIS	90° AXIS																																																			
	1.0000			New	1.00	A																																																					
	inches					B																																																					
						C																																																					
Remarks: _____ (State of the art condition)																																																											
The above measurements were taken under environmental conditions of 30-50% relative humidity and 68° ± 1°F (20° ± .56°C). Gages are calibrated with standards that are reported accurate and traceable to the National Institute of Standards and Technology. Calibration and Maintenance of the equipment and reference standards used in this inspection conforms to ANSI/NCSL Z540-1-1994 and ISO/IEC 17025.																																																											
Uncertainty of Measurement in: micrometers <u>10</u>					Traceable Report No: <u>821273187-06</u>																																																						
Inspector: <u>Ruben Vasquez</u>					Report Date: _____																																																						
This report may not be reproduced, except in full, without the express written approval of Western Gage Corporation. The recalibration interval for items calibrated on this report is to be determined by the user.																																																											
LIMITED WARRANTY This report shows data obtained by a qualified technician under carefully controlled conditions. In rare instances, operator error or mismarking of the gage or report may occur. Any gage manufactured by Western Gage and not conforming to the reported size and class tolerance, allowing for the established measurement uncertainty, will be reworked or replaced at no charge. If returned to Western Gage's Camarillo facility within 90 days of shipment, No liability for consequential damages or other costs related to a nonconforming or mismarked gage is expressed or implied in this report.																																																											

Setting Master Dimensional Data

See page 27 for order codes

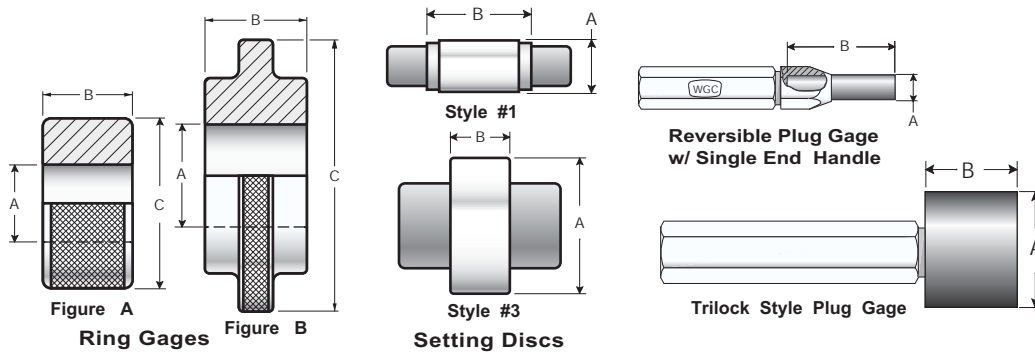

Ring Gage Masters				
Diameter A above - incl.	Dia. C	Dim. B	Gage Blank #	Figure
.040 - .060	.94	.19	00**	A
.060 - .070	.94	.25	sp**	A
.070 - .230	.94	.37	0**	A
.230 - .365	1.13	.56	1	A
.365 - .510	1.38	.75	2	A
.510 - .825	1.75	.94	3	A
.825 - 1.135	2.13	1.13	4	A
1.135 - 1.510	2.50	1.31	5	A
1.510 - 2.010	4.00	1.50	6	B
2.010 - 2.510	4.50	1.50	7	B
2.510 - 3.010	5.00	1.50	8	B
3.010 - 3.510	5.50	1.50	9	B
3.510 - 4.010	6.38	1.50	10	B
4.010 - 4.760	7.25	1.50	11	B
4.760 - 5.510	8.25	1.50	12	B
5.510 - 6.260	9.25	1.50	13	B
6.260 - 7.010	10.30	1.50	14	B
7.010 - 7.760	11.30	1.50	15	B
7.760 - 8.510	12.30	1.50	16	B
8.510 - 9.100	13.30	1.50	17	B

** In these sizes, Western provides a blank that is thicker than the A.N.S.I. standard for more reliable gage mastering.

Set Disc Masters		
Diameter A above - incl.	Dim B	Gage Style
.150 - .230	1.19"	1
.230 - .365	1.31"	1
.365 - .510	1.44"	1
.510 - .825	1.56"	1
.825 - 1.135	1.69"	1
1.135 - 1.510	1.94"	1
1.510 - 2.510	.88"	3
2.510 - 8.010	1.00"	3

Master Setting Plugs		
Diameter A above - incl.	Dim B	Gage Style
.060 - .825	2.00"	Reversible
.825 - .947	1.25"	Trilock
.947 - 1.135	1.37"	Trilock
1.135 - 1.510	1.50"	Trilock
1.510 - 2.010	.88"	Trilock
2.010 - 3.510	1.00"	Trilock
3.510 - 8.010	1.00"	Trilock

AMERICAN GAGE DESIGN TOLERANCES					
Size above -incl. inch / mm	Tolerance - inch / μm				
	XXX	XX	X	Y	Z
.029 - .825	.00001	.00002	.00004	.00007	.00010
.74 - 20.96	.25	.51	1.02	1.78	2.54
.825 - 1.510	.000015	.00003	.00006	.00009	.00012
20.96 - 38.35	.38	.76	1.52	2.29	3.05
1.510 - 2.510	.00002	.00004	.00008	.00012	.0001
38.35 - 63.75	.51	1.02	2.03	3.05	4.06
2.510 - 4.510	.000025	.00005	.00010	.00015	.0002
63.75 - 114.55	.64	1.27	2.54	3.81	5.08
4.510 - 6.510	.000033	.000065	.00013	.00019	.00025
114.55 - 163.35	.83	1.65	3.30	4.83	6.35
6.510 - 9.010	.00004	.00008	.00016	.00024	.00032
163.35 - 228.85	1.02	2.03	4.06	6.10	8.13

Bilateral / Unilateral Tolerances

A.G.D. classes define the total tolerance zone for the gage. Master gages are made with the A.G.D. class tolerance split equally (bilaterally). Go and NoGo fixed limit gages for functional testing of workpieces are normally unilaterally toleranced into the tolerance zone of the part. Thus, "Go Rings" and "No-Go Plug" gages are unilaterally minus toleranced. "No-Go Rings" and "Go Plug" gages are unilaterally plus toleranced. For example, a .5000" master ring gage, with a class "XX" tolerance (.00002") is finished to a diametrical tolerance of ±.00001". Ordered as a No-Go ring gage, the .5000" ring would be finished to +.00002"/.00000" diametrical tolerance.

Air Gage Series Classifications & Interchangeability

Interchangeability The compatibility of various makes of air gage readouts and gaging members varies widely. Readouts designed for single setting master operation have factory preset sensitivities, and must be operated with gaging members that have gaging nozzles with matching sensitivities. Readouts with user adjustable metering valves can accommodate most makes of gaging members, but they must be scaled using two setting masters for each air gage member. Western's air gage readouts can be configured to operate both single and dual mastered gaging members but this choice must be specified when ordering.

Series classifications are used to define air gage members and air gage readout instruments that are compatible. Order codes for gaging members utilize two digit series classifications in which the first digit indicates the type of readout the member is intended to be operated with, and the last digit indicates the nominal operating clearance between the gaging member and the workpiece.

Series 10 Air gage members are designed to operate with back pressure type instruments incorporating user adjustable metering valves. These instruments accommodate a wide range of nozzle sizes, so practically all sizes of gaging members can be operated. Being user calibrated, two setting masters are required for each gaging member.

Series 40 & 50 Air gage members are designed for use with flow meter type "glass tube" column instruments. These readouts require series 40 members that have .078" jets in order to obtain the magnifications marked on the flow tubes. Series 50 air gage member are for use on columns with fractional amplification scales that correct for the reduction in magnification that occurs when smaller than standard jets are used. Series 10 gaging members have significantly larger nozzle recess depths than the series 40 & 50 members and, generally will not operate on flowmeter columns, but series 10 readouts will operate series 40 and 50 gaging members.

Series 60 thru 80 Readouts are back pressure type instruments intended for single master operation. Flow restrictors in these instruments are not user adjustable. They are factory calibrated to predetermined pneumatic scale factors using master test orifices. Gaging members made for these instruments have gaging nozzles that are sized to match the scale factor of the readout series with which they are to be used. Note that series 70 gaging members utilize smaller jets, cost more, and have less gaging range than series 60 members, consequently it is recommended that they be used only in applications requiring small jet holes.

DUAL MASTER SYSTEMS

Series 10 Air gage members- use on **Western Gage Corporation spec 10 Readouts**

Also:

Edmunds Gage
Moore Products
Air Gage Products (El Segundo, CA)
Air Gage Company (Livonia, IL)
Sheffield A-E columns
Other adjustable dial type gages & adjustable air-electronic columns

Series 40 Air gage members- use on Sheffield flow meter (glass tube) columns with full amplification scales. Series 40 members require .078" jets and are not available in sizes below .323".

Series 50 Air gage members- use on Sheffield flow meter (glass tube) columns with fractional amplification scales. These members utilize smaller than .078" air jets.

SINGLE MASTER SYSTEMS

Series 60

Spec. 63 Air gage members- use on **Western Gage Readouts calibrated Series 60** or Mahr-Federal Dimensionair D-5000, D-8000, EAG-32XXX (Scale $\pm .00075$ " Tool Code 20)

Spec. 64 Air gage members- use on **Western Gage Readouts calibrated Series 60** or Mahr-Federal Dimensionair D-2500, D-4000 / EAG-31XXX (Scale $\pm .0015$ " Tool Code 50)

Series 70

Spec. 71 Air gage members- use on **Western Gage Readouts calibrated Series 70** or Mahr-Federal Dimensionair D-20000, D-32000 / EAG-34XXX (Scale $\pm .00015$ " Tool Code 5)

Spec. 72 Air gage members- use on **Western Gage Readouts calibrated Series 70** or Mahr-Federal Dimensionair D-10000, D-16000 / EAG-33XXX (Scale $\pm .0003$ " Tool Code 10)

Series 80

Spec. 85 Air gage members- use on **Western Gage Readouts calibrated Series 80** or Mahr-Federal Dimensionair D-1250 / EAG(N.A.) (Scale $\pm .003$ " Tool Code 100)

Western Gage's sales & engineering staff is available to assist with determining your air gage specifications.

Sample Order Codes & Check Lists

AIR PROBES & AIR RINGS

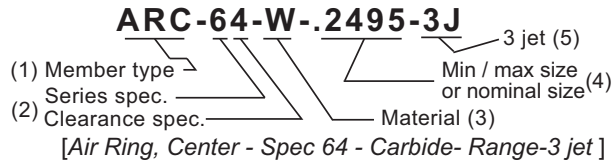
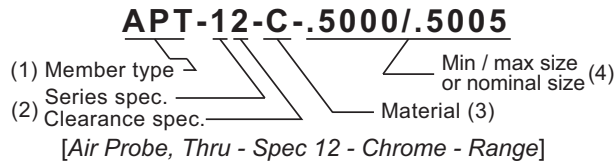

Check List for Air Probes & Air Rings

(1) Gaging member type order code

Air Probe, Thru-hole	APT
Air Probe, Blind	APB
Air Probe, Super blind	APS
Air Ring, Center jet	ARC
Air Ring, Shoulder	ARS
Air Ring, extra close	ARX

(2) Series specification Match the gage series that includes the Readout with which it will be used, then complete the gaging member specification by changing the last digit of the series number to show the clearance specification. Pages 18 & 20 show standard clearances for dual and single master systems.

(3) Material order code

Steel	S
Chrome	C
Carbide	W
CPM-10V (Premium wear resistant tool steel)	V

(4) Size of the setting master(s)

Gaging members for Series10 - 50 comparators require that both minimum and maximum setting master sizes be specified. Series 60 thru 80 members require only the nominal size. Add suffix "mm" to denote millimeter sizes.

(5) Special requirements -- modifications required for the application such as:

Three Jets - add suffix "-3J" to order code.(Two-jet members are furnished unless otherwise specified).

Extra length - Extra length is required for small air probes to gage deep holes -- add suffix "-XLC" and specify the jet to handle dimension ["C"]. -- see illustration below.

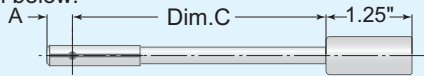

APT-64-C-.2495-XLC-3.00"
Dim. C

Other specials - for modification to standard blanks not requiring a custom drawing, add suffix "-SP" and specify modification in remarks field.

(6) Special marking. Gaging member sizes are marked on all members. Customer tool numbers will be added upon request. Numbers with more than 10 characters are subject to additional charges.

SETTING MASTERS

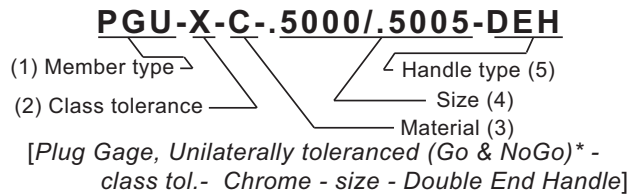
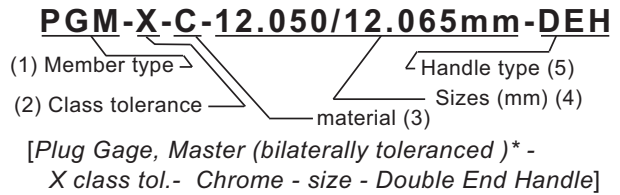
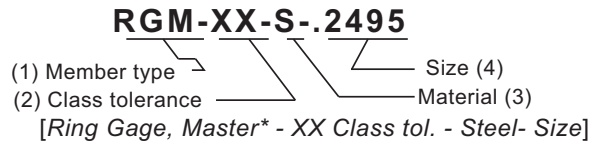

* see notes on bilateral & unilateral class tolerances on page 25.

Check List for Setting Masters

(1) Specify member type order codes

Ring Gage, Master	RGM
Ring Gage, Go	RGG
Ring Gage, NoGo	RGN
Plug Gage, Master	PGM
Plug Gage, Go	PGG
Plug Gage, NoGo	PGN
Plug Gage, Go/NoGo set	PGU
Set Disc, (ANSI B47.1 style 3)	SDS
Set Disc, (ANSI B47.1 style 1)	SDL

(2) Specify class tolerance Select class tolerance Z thru XXX from the table pg-25. Bilaterally toleranced master gages are recommended for air gage applications.

(3) Material order codes

Steel	S
Chrome	C
Carbide	W

(4) Specify size(s) of setting master Sizes are assumed to be in inches unless followed by "MM"(millimeters). **Careful checking of required size prevents expensive mistakes.**

(5) Select handle type (Plug gages only)

Single end handle	SEH
Double end handle	DEH
Member only	M/O

(6) Specify marking Size and class tolerance are marked on all master gages. Customer tool numbers up to ten characters will be marked at no charge.

PRODUCTION GAGING SOLUTIONS

Fast, Accurate Taper Gages & Applications



A.N.S.I. Steep Machine Tool Tapers. 3.5 in / ft. with or without flange contact.



I.S.O HSK 1:9.98 taper ratio and Kennametal KM Tapers with flange contacts.



Medical implant self-holding Tapers. Femoral stem and ball socket shown above.

Connected to tapered air probes and air ring gages, Micro II_i readouts are a fast and accurate means of checking taper angles and related reference diameters.

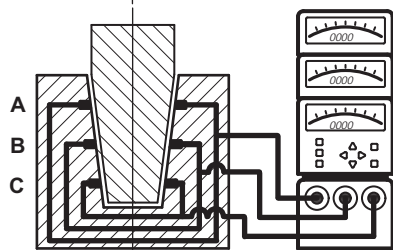

Taper Air Ring Gage

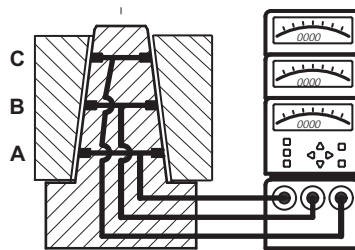

Taper Air Probe

Taper specifications

Taper designs may be specified by an included angle and an angularity tolerance; or the slope may be defined as "Basic" and a "form or contour" tolerance applied to the profile. In either case a datum controlling the size of the taper must be located at some point on the taper. Referred to as a "Reference or Datum diameter", this dimension relates the taper to some feature on the workpiece, such as an adjacent shoulder or a theoretical sharp corner at one end of the taper.

Readout selection

Tapers specified with angularity tolerances require readouts that utilize "A-B" and "A-C" calculation functions to display angularity deviations. Tapers utilizing contour tolerances require direct coupled readouts that display the profile tolerance limits at each set of sensors. **Micro II_i Readouts** can be configured to check either angular deviations or contour toleranced tapers. See table of order codes for taper gages at right.

Two or Three air circuits

Taper gages that incorporate three air circuits allow the user to determine if hourglass or barrel shapes are super imposed on taper profiles. They are preferred on long tapers where this profiling error is most common, however space limitations often prohibit including the third circuits on short tapers.



Micro II_i Readouts for Tapers Model Numbers & Applications

Readout for taper seating applications only:
AEQ-42-12M Dual circuit with single (A-B) display. (Available as a single mastered readout only.)

Readouts for taper or shoulder seating applications:

AEQ-42-22M Dual circuit with (A) & (A-B) displays.

AEQ-42-32N Dual circuit with (A), (B) & (A-B) displays.

AEQ-42-33M Triple circuit with (A), (A-B) & (A-C) displays.

Readouts for applications with a contour tolerance controlling the "basic" taper profile:

AEQ-42-22 Dual circuit with (A) & (B) displays.

AEQ-42-33 Triple circuit, with (A), (B) &

PRODUCTION GAGING SOLUTIONS . . . Taper Gages



Dual circuit air taper probe mounted on base with setting master

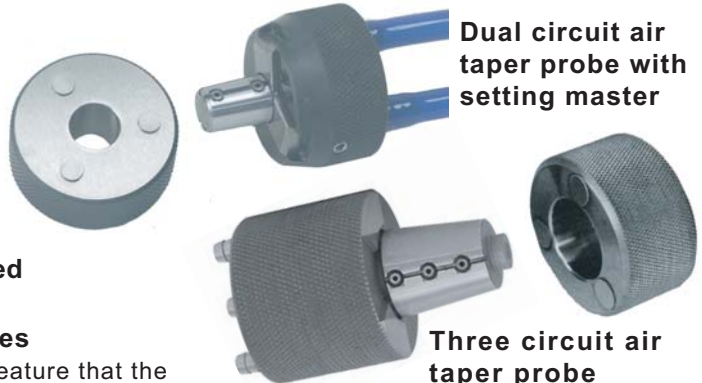

Dual circuit air taper probe with setting master

Three circuit air taper probe

Shoulder seating vs Taper seating gages

Taper gages can be designed to seat on the feature that the taper is referenced to, such as an adjacent shoulder, or they may be allowed to seat on the tapered surface itself -- see illustration at right. The shoulder seating design allows measurement of a reference datum diameter on the taper as well as angular deviation. This design is preferred where the tolerance on the reference datum diameter is closely held. For applications where a reference diameter is not closely held, a taper seating design is preferred in order to avoid excessive clearance. HSK machine tool tapers and most medical implant tapers are designed to shoulder seat, while nonflange seating American Steep Machine tool holders and many shaft end tapers are design to taper seat.

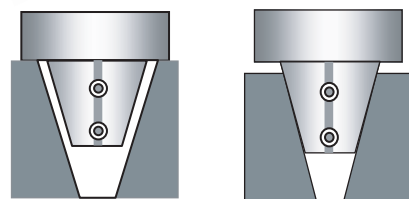

Shoulder seating air taper gage

Taper seating design

HSK Shoulder Seating Taper per I.S.O. 12164-1

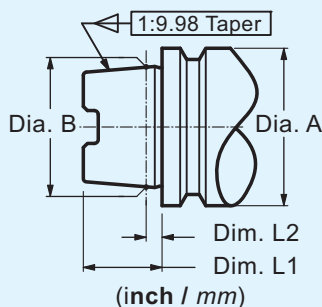

No.	Dia.A	Dia. B	Dim.L1	Dim.L2
40	1.575 40	1.1814 30.007	.7874 20	.1575 4.0
50	1.968 50	1.4964 38.009	.9843 25	.1968 5.0
63	2.480 63	1.8902 48.010	1.2598 32	.2480 6.3
80	3.150 80	2.3663 60.012	1.5748 40	.3150 8.0
100	3.937 100	2.9533 75.013	1.9685 50	.3937 10.0

Above data are provided for product identification -- see I.S.O. spec and factory gage drawing for complete specifications.

Machine Tool Holder Steep Tapers per A.N.S.I. B5.10

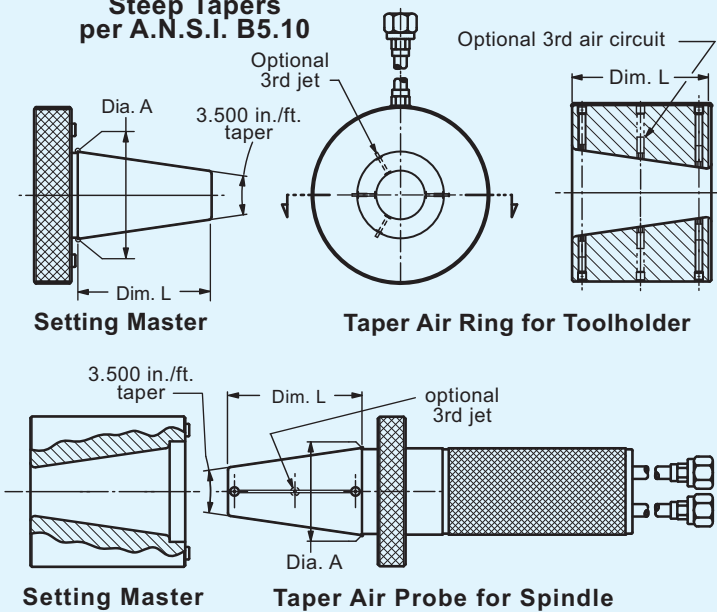

Above data are provided for product identification -- see ANSI spec and factory gage drawing for complete specifications.

No.	Dia. A	Dim L
30	1.250	1.8750
40	1.750	2.5625
45	2.250	3.3125
50	2.750	4.0000
60	4.250	6.3750

(inch)

Custom Taper Gage Applications -- Send us a drawing of your taper for our engineering review and gage proposal.

PRODUCTION GAGING SOLUTIONS . . Custom Air Spindles

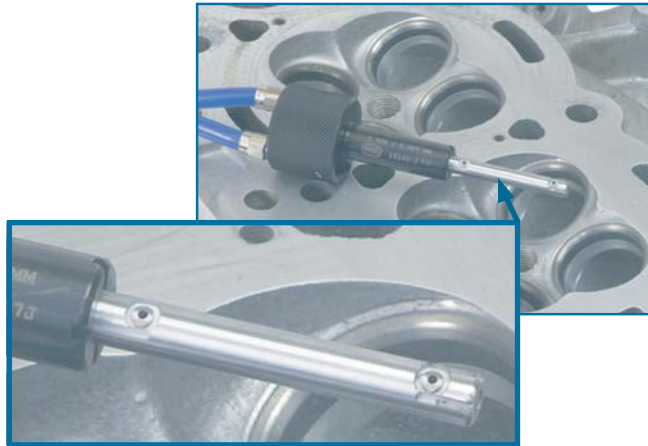

Dual Circuit Air Probes provide rapid inspection of valve guide internal diameters.



Four Circuit Air Probes provide fast-accurate inspection of internal lands in hydraulic valve housings.



Air Straightness Gages check the straightness of internal diameters in valve housings and similar parts.



Dual Circuit Six Jet Air Probes check average diameter at two places in wrist pin bores.



Leaf Jet Air Probes check bores with rough surface finishes or lands too narrow for gaging with open jets.

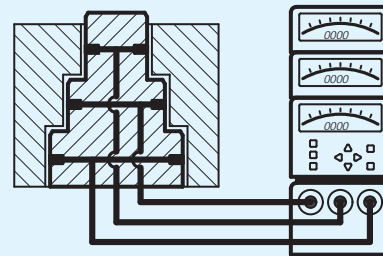

Multi-circuit Air Spindles provide simultaneous measurements at multiple locations.

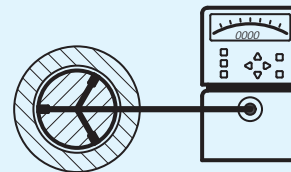

Three Jet Air Probes accurately measure 3 lobed out-of-round conditions not detectable with two jet probes.

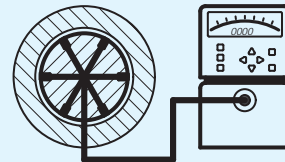

Six Jet Air Probes measure the average diameter of thin walled parts

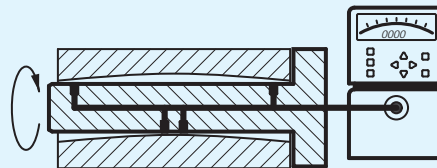

Air Straightness Gages check the "banana" shape of long bores. Rotating the air spindle displays the straightness error.

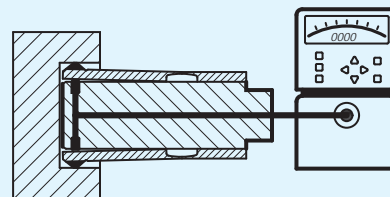

Leaf Jet Air Probes incorporate carbide tip styluses to measure the workpiece. Use these on rough surfaces for the best correlation to measurements with other gaging methods.

PRODUCTION GAGING SOLUTIONS Flatness & Thickness Gages

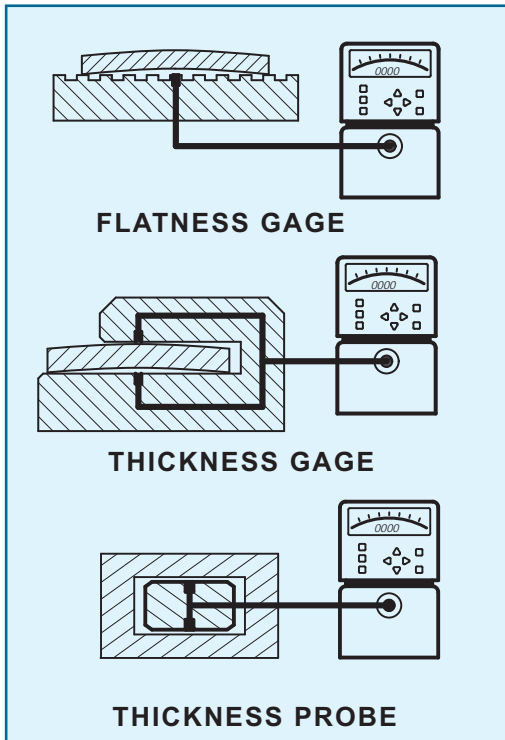

Adjustable Air Thickness Gage

Detail view shows the lower air jet. Models with larger anvils are available.

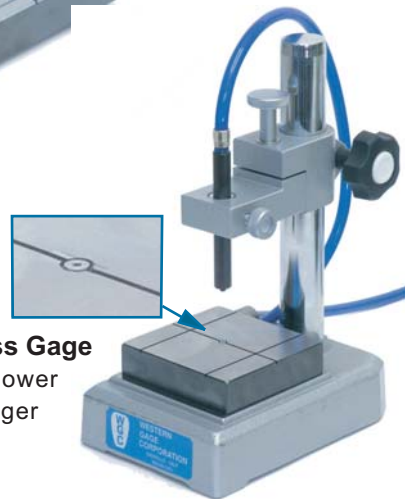

Open Jet Gaging Cartridges are used with Flatness and Thickness gages and similar applications. (See illustrations at the right).

Model ACR has right angle hose connection and mounting screws for installation in surface plates. (Requires drilling the plate and installing a bushing).

Model ACS is used on thickness gages and similar applications.

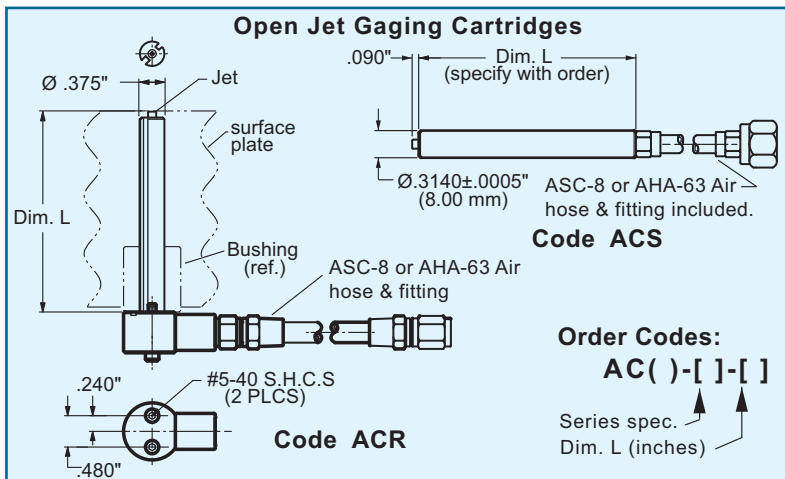

PRODUCTION GAGING SOLUTIONS . . . Fast-Accurate Gages

Spherical Air Probes measure female spherical sockets. Applications include hydraulic motor swash plate pads, I.C. engine push rods and medical implants. Fig.A



Film Thickness
Checks film thickness on calendar mill as material is processed.

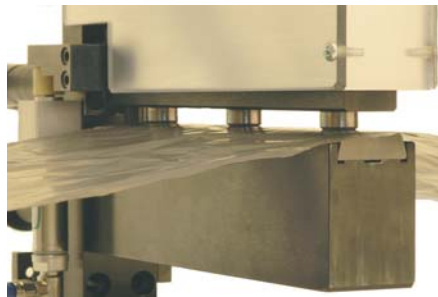

Orifice flow testing using Micro II_i Readouts provides an efficient means of controlling the quality of small orifices. Applications include natural gas burner orifices, pesticide sprayer nozzles, and fuel systems components. Test fixture with orifice shown at right.



Fig.C

Inspection fixtures incorporating pairs of staggered air jets are a rapid means of checking bore to face runouts. Inspection times of 10 to 20 seconds per part are typical. Use the Micro II_i or GageChek's "TIR" recording function to facilitate data capture and evaluation. (Note that using this inspection method, the Total Indicated Readings obtained are twice the perpendicularity tolerance as defined in the ASME/ANSI Y14.5M specification). Fig.D

Bore to bore runouts utilizing secondary datums can be inspected using fixtures as illustrated in Fig. E

Bore to bore runouts without secondary datums can be inspected if one of the diameters is of adequate length -- see Fig.F.

Perpendicularity, Concentricity, and True position callouts may require additional air nozzles, air circuits and multiple input readouts to prevent "out-of-round" conditions from influencing the gage readings. Consult Western Gage engineering for application feasibility.

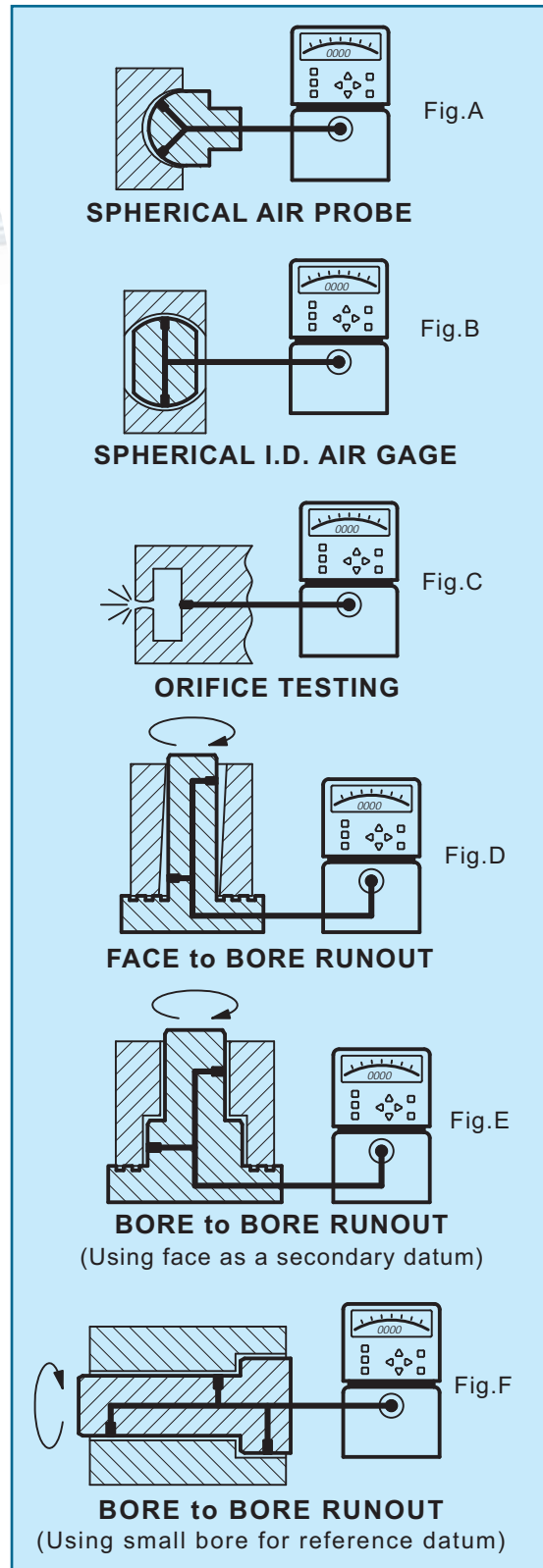

GAGING SOLUTIONS . . Fast, Accurate Air Gage Fixtures

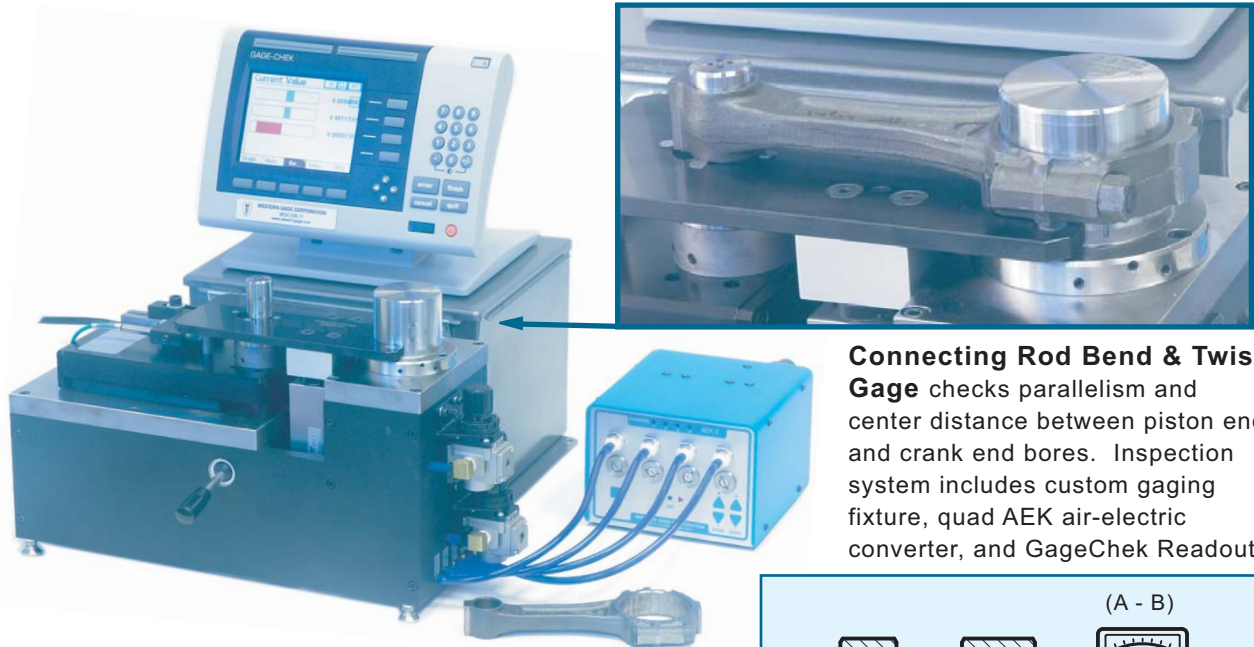

Connecting Rod Bend & Twist Gage checks parallelism and center distance between piston end and crank end bores. Inspection system includes custom gaging fixture, quad AEK air-electric converter, and GageChek Readout.



Three Spindle Inspection station checks bore size, O.D. size, I.D. to O.D. concentricity, and bore to face perpendicularity on machined bearing housing. Uses 3 quad AEK air/electric converters coupled to CWK-2 computer. (Images Above)

Canister Bore Inspection Station. Stepper motor driven slide moves an air probe to measure internal diameter at multiple locations. Integrated with WGC's AEK & GageChek. (Image at right)

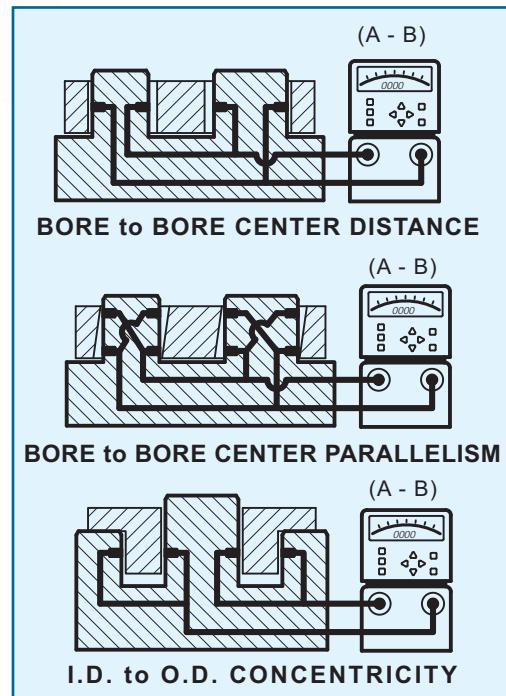

PRODUCTION GAGING SOLUTIONS LVDT Gages

For fast and accurate gaging solutions, LVDT sensors provide hard contact gages with extended gaging ranges and excellent linearity.



LVDT Gaging Probe



LVDT Flexure Gage



LVDT Block Gage

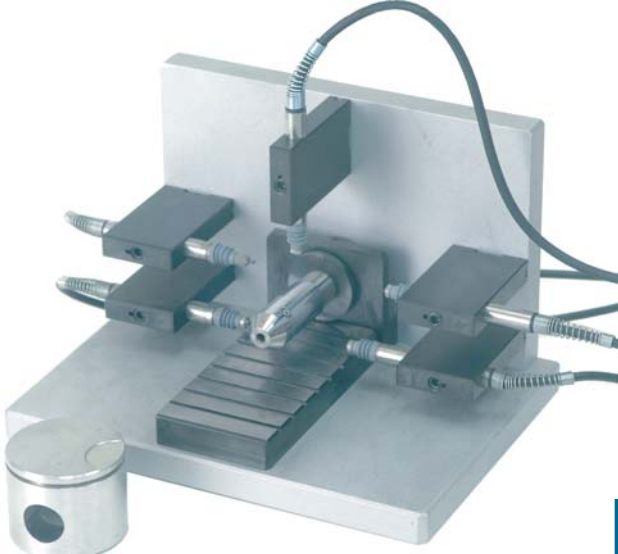

Piston Inspection Fixture utilizes LVDT Probes to check O.D.s and Air Probe to check I.D.s.

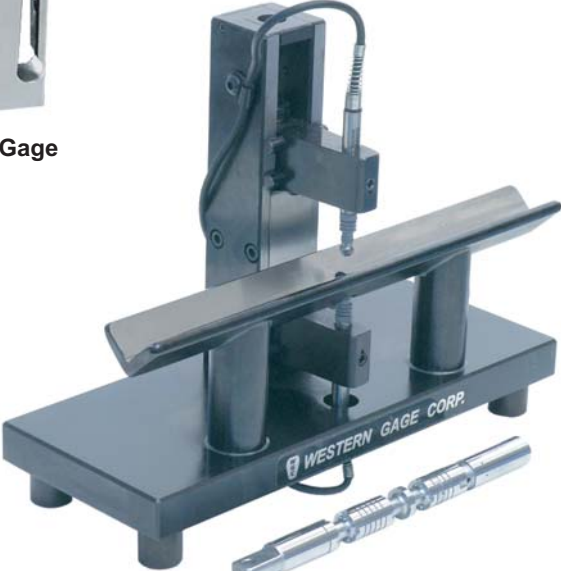

Vee Gage checks hydraulic valve spool O.D.s utilizing opposed set of LVDT Probes.

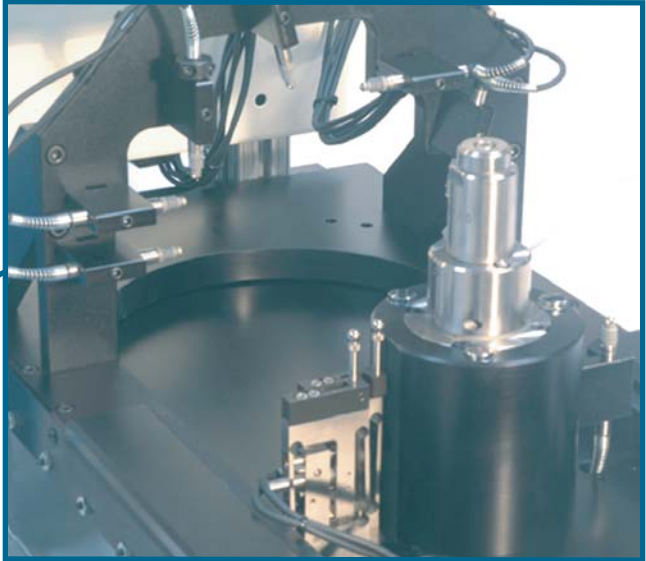
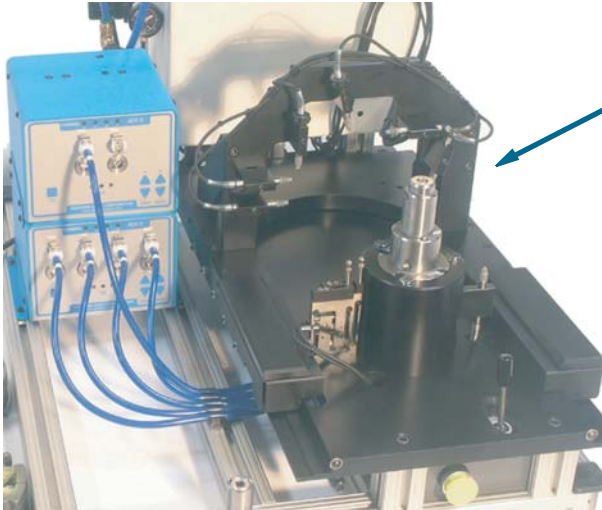

Air Spindle, LVDT Probes & Flexure Gages used in inspection stations for scroll compressor parts.

LVDT GAGES AND ACCESSORIES

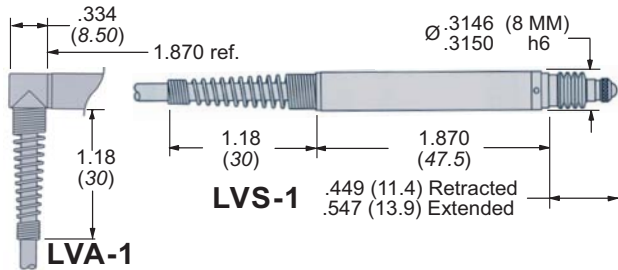

LVS-1 Spring push type LVDT gaging cartridge with internal linear ball bushing guide, viton gaiter, Ø 3 mm carbide ball tip and 2 meter cable with Hirose 7 mm connector [P/N HR10-7P-6P (73)]
 Gaging range ... ± 1 mm
 Pretravel .15 mm
 Tip force 70 gm±20%
 Linearity 0.5% of Reading
 Tips are threaded M2.5x.45 (see optional tips below). Other ranges are available on special order.

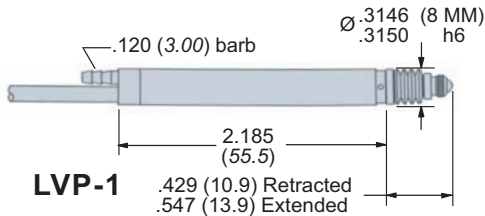

LVA-1 Right Angle Adapter kit for LVS-1 gaging cartridges.

LVP-1 Pneumatic push LVDT probe. Same specifications as LVS-1 probe except as follows:

Tip force 82 gm @ 6 psi
 285 gm @ 15 psi
 Pretravel .30 mm
 (Max. pressure 15 psi)

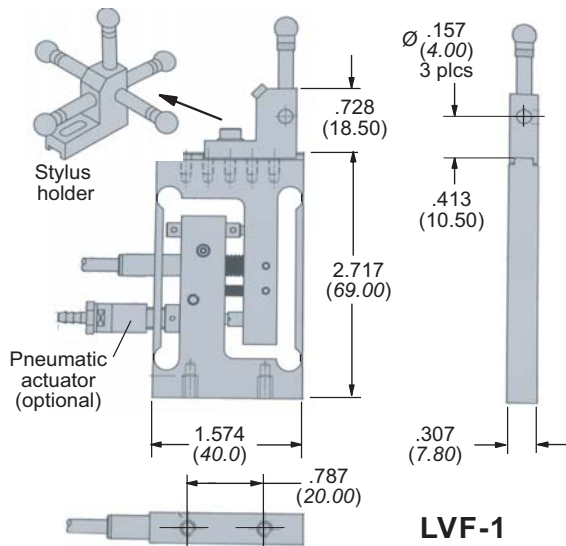

LVF-1 LVDT sensor integrated in parallelogram flexure motion transfer linkage. Electrical specifications are the same as LVS-1, add suffix "P" to include pneumatic actuator.

LVR-1 Reverse acting version of LVF-1

LVB-1 LVDT sensor integrated in block style transfer mechanism using linear ball bearings. More rugged and available with greater gaging range than flexure style, but side play limits the gaging accuracy in tight tolerance applications. Electrical specifications are same as LVS-1.

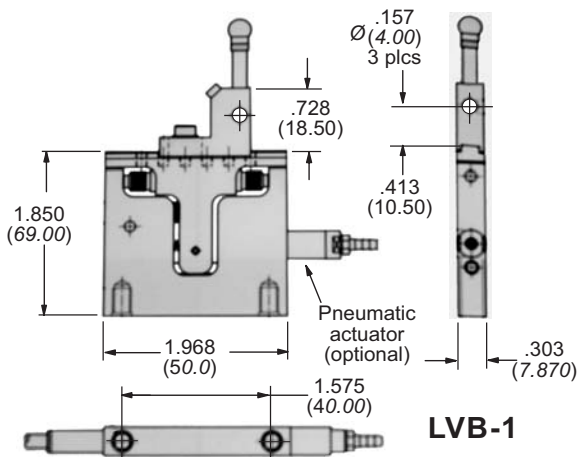

Probe Tips M2.5x0.45

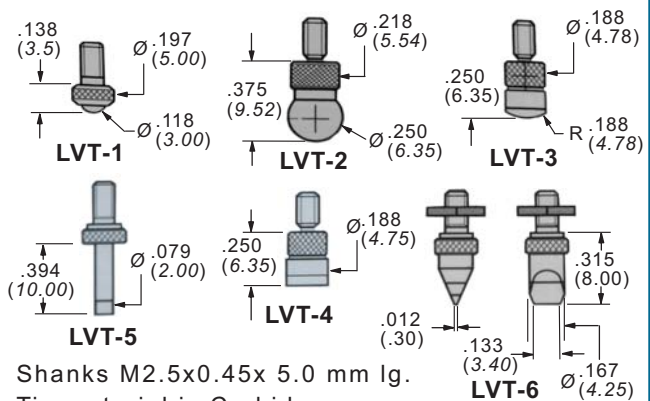



Western Gage Corporation has provided solutions for industry's dimensional measurement requirements with high quality air and electronic gages since 1968.



WESTERN GAGE CORPORATION

3316-A Maya Linda

Camarillo, CA 93012-8059

(800) 423 5062 (Toll free) (805) 445 1410 (local) (805) 445 7530 (FAX)

Visit us on line at www.westerngage.com

or email us at sales@westerngage.com